

**WANG**

7302

**BINARY SYNCHRONOUS  
COMMUNICATIONS OPTION**

**Model: 5528**

**Customer Engineering  
Product Maintenance Manual**

**741-0681**

## PREFACE

The purpose of this manual is to provide the Wang-trained Customer Engineer (CE) with instructions to operate, troubleshoot and repair the Binary Synchronous Communications Option.

Word Processing Newsletters No. 48.3A and No. 48.4 are located at the back of the manual.

First Edition (1979)

This edition of the Binary Synchronous Communications Option manual is the converted number for 729-0681-A. It also incorporates Word Processing Newsletters no. 729-0681-4 and no. 729-0681-5. This edition may be used only for the purpose stated in the Preface. Updates and/or changes to this document will be published as Publication Update Bulletin's (PUB's) or by subsequent editions.

This document is the property of Wang Laboratories, Inc. All information contained herein is considered company proprietary, and its use solely is restricted for the purpose of assisting the Wang-trained CE in servicing this Wang product. Reproduction of all or any part of this document is prohibited without the prior consent of Wang Laboratories, Inc.

1.	INTRODUCTION .....	1-1
1.1	WORD PROCESSOR TELECOMMUNICATIONS .....	1-1
1.2	THE BINARY SYNCHRONOUS COMMUNICATIONS OPTION .....	1-2
2.	INSTALLATION .....	2-1
2.1	PRE-INSTALLATION PROCEDURES .....	2-1
2.2	SYSTEM REQUIREMENTS .....	2-2
2.3	INSTALLATION PROCEDURE .....	2-3
2.3.1	SITE SELECTION .....	2-3
2.3.2	D.C. VOLTAGE ADJUSTMENTS ON REGULATOR BOARD.....	2-3
2.3.3	ADDRESS SWITCH SETTINGS .....	2-5
2.3.4	INSTALLATION .....	2-5
2.4	MODEL 5528 COMMUNICATIONS CONTROLLER SPECIFICATIONS .....	2-9
2.5	MODEM REQUIREMENTS .....	2-10
2.6	MODEL 5528 COMMUNICATIONS CONTROLLER FRONT PANEL INDICATORS .....	2-11
3.	BINARY SYNCHRONOUS COMMUNICATIONS SOFTWARE .....	3-1
3.1	2780/3780 EMULATION DESCRIPTION AND SPECIFICATIONS .....	3-1
3.2	TC RELEASE 15.1T2 AND 5.1T2 .....	3-3
3.2.1	INTRODUCTION .....	3-3
3.2.2	NULL MODEM LINE SPEEDS .....	3-4
3.2.3	RECORD BLOCKING .....	3-4
3.2.4	TIMEOUT LOGIC .....	3-4
3.2.5	SPECIAL TRANSMIT CHARACTERS .....	3-5
3.3	PROCEDURE FOR LOADING COMMUNICATIONS ONTO AN EDITING STATION/WP10A/WP20 .....	3-6
3.4	PROCEDURE FOR LOADING COMMUNICATIONS ONTO A WP30 .....	3-10
3.5	BSC EMULATOR OPERATING INSTRUCTIONS .....	3-14
3.5.1	PREPARING TO SEND OR RECEIVE DOCUMENTS .....	3-14
3.5.2	SCHEDULING A TELECOMMUNICATIONS SESSION .....	3-17
3.5.3	THE BACKGROUND ACTIVITY .....	3-22
3.5.4	CHECKING THE SESSION QUEUE .....	3-22
3.5.5	ESTABLISHING A CONNECTION .....	3-24
3.5.6	VERIFYING SUCCESSFUL COMMUNICATIONS .....	3-25
3.5.7	CANCELING A SESSION .....	3-27
3.5.8	ABORTED SESSIONS .....	3-28
3.6	SOFTWARE CORRECTIONS AND IMPROVEMENTS .....	3-29
3.7	SOFTWARE RESTRICTIONS .....	3-31
3.8	ERROR MESSAGES ISSUED DURING TC SYSTEM UPDATING .....	3-32
3.9	BSC DATA TRANSLATIONS .....	3-33
3.9.1	INTRODUCTION .....	3-33
3.9.2	DATA TRANSLATION .....	3-34
3.9.3	WWPS-to-WWPS DATA FORMAT .....	3-34
3.9.4	WWPS-to-HOST TRANSPARENT DATA FORMAT .....	3-35
3.9.5	WWPS-to-HOST NON-TRANSPARENT DATA FORMAT .....	3-35
3.9.5.1	GENERAL .....	3-35
3.9.5.2	INTERMEDIATE DATA FORMAT .....	3-36
3.9.5.3	DOCUMENT TO INTERMEDIATE TRANSLATION .....	3-37
3.9.5.4	TRANSMIT DATA TRANSLATION .....	3-37
3.9.5.5	RECEIVE DATA TRANSLATION .....	3-39
3.9.5.6	INTERMEDIATE DATA TO DOCUMENT TRANSLATION .....	3-41

3.10	COMMUNICATION SOFTWARE DESCRIPTION .....	3-48
3.10.1	COM DISK PROGRAM MODULE LOCATIONS .....	3-48
3.10.2	TC COMMUNICATIONS CONTROLLER MEMORY LAYOUT .....	3-50
3.10.3	TC MODULES AND CONTROL BLOCKS .....	3-50
4.	DIAGNOSTICS .....	4-1
4.1	ON-LINE TC DIAGNOSTICS .....	4-1
4.1.1	INTRODUCTION .....	4-1
4.1.2	EQUIPMENT REQUIREMENTS .....	4-1
4.1.3	TC TEST OPERATION USING THE DIAGNOSTIC COMMAND PROCESSOR .....	4-1
4.1.4	OPERATION USING THE DEDUG MONITOR .....	4-5
4.1.5	TECHNICAL DESCRIPTION .....	4-6
4.2	ON- LINE SYSTEM CHECKOUT .....	4-19
4.3	LINE MONITOR TESTER .....	4-23
4.3.1	INTRODUCTION .....	4-23
4.3.2	DESCRIPTION .....	4-23
4.3.3	OPERATION .....	4-24
4.3.4	HOW TO TROUBLESHOOT THE SYSTEM USING THE LINE MONITOR .....	4-28
4.4	GENERAL SYSTEM TROUBLESHOOTING HINTS .....	4-30
4.4.1	INTRODUCTION .....	4-30
4.4.2	TROUBLESHOOTING CHECKLIST .....	4-30
4.4.3	MODEM CONTROL SIGNALS CHECKOUT .....	4-31
4.4.4	MODEM SELF TESTS .....	4-34
4.4.4.1	DATA SET 201C SELF TESTS .....	4-34
4.4.4.2	DATA SET 208B SELF TESTS .....	4-38
4.5	TC SOFTWARE TROUBLESHOOTING PROCEDURE .....	4-45
4.5.1	TC FAILS TO OPERATE .....	4-45
4.5.2	ABORTED SESSIONS .....	4-47
4.6	EIA INTERFACE TEST SET .....	4-47
5.	ENGINEERING CHANGE NOTICES (E.C.N.'s) .....	5-1



## APPENDIX A DETAILED DESCRIPTION OF BISYNC COMMUNICATIONS

### A.1 INTRODUCTION

- A.1.1 SYNCHRONOUS TRANSMISSION
- A.1.2 BINARY SYNCHRONOUS COMMUNICATIONS PROCEDURE
- A.1.3 THE DATA LINK
- A.1.4 TRANSMISSION CODES

### A.2 OPERATION OF THE DATA LINK

- A.2.1 MESSAGE BLOCKS
- A.2.2 ERROR CHECKING
  - A.2.2.1 VRC/LRC
  - A.2.2.2 CRC12/CRC16
  - A.2.2.3 EOT/NAK PAD FORMAT
- A.2.3 DATA-LINK CONTROL
  - A.2.3.1 SYN - SYNCHRONOUS IDLE
  - A.2.3.2 SOH - START OF HEADING
  - A.2.3.3 STX - START OF TEXT
  - A.2.3.4 ETB - END OF TRANSMISSION BLOCK
  - A.2.3.5 ITB - END OF INTERMEDIATE TRANSMISSION BLOCK
  - A.2.3.6 ETX - END OF TEXT
  - A.2.3.7 EOT - END OF TRANSMISSION
  - A.2.3.8 ENQ - ENQUIRY
  - A.2.3.9 ACKO/ACK1 - AFFIRMATIVE ACKNOWLEDGEMENT
  - A.2.3.10 WACK - WAIT-BEFORE-TRANSMIT POSITIVE ACKNOWLEDGEMENT
  - A.2.3.11 NAK - NEGATIVE ACKNOWLEDGEMENT
  - A.2.3.12 DLE - DATA LINK ESCAPE
  - A.2.3.13 RVI - REVERSE INTERRUPT
  - A.2.3.14 TTD - TEMPORARY TEXT DELAY
  - A.2.3.15 DLE EOT - DISCONNECT SEQUENCE FOR A SWITCHED LINE

### A.3 MESSAGE FORMATS FOR BASIC OPERATION

- A.3.1 HEADINGS
- A.3.2 TEXT
- A.3.3 POINT-TO-POINT OPERATION
- A.3.4 ADDITIONAL FORMAT CONSIDERATIONS
  - A.3.4.1 SYNC PATTERNS
  - A.3.4.2 TIMEOUTS

### A.4.4 I/O AND BUFFER CHECK

### A.5 TIMEOUT CONTROLS

- A.5.1 ONE-SECOND TIMEOUT
- A.5.2 TWO-SECOND TIMEOUT
- A.5.3 THREE-SECOND TIMEOUT
- A.5.4 EXTENDED ENQ RETRY FEATURE
- A.5.5 STANDARD 2780 OPERATION
- A.5.6 2780 OPERATION WITH EXTENDED RETRY TRANSMISSION FEATURE INSTALLED

- A.6.1 MULTIPLE RECORD TRANSMISSION
- A.6.2 EBCDIC TRANSPARENCY

A.7 DATA LINK CONTROL FORMAT

- A.7.1 SERIALIZER SYNCHRONIZATION
- A.7.2 FORMAT, RESPONDING TO TRANSMISSION OF TEXT
- A.7.3 FORMAT, EOT RESPONSE OR INCOMPLETE TRANSMISSION
- A.7.4 FORMAT, ERROR CONDITIONS
- A.7.5 FORMAT, RETRANSMISSION

A.8 SUMMARY OF RESPONSES TO ERRORS

- A.8.1 NAK
- A.8.2 EOT
- A.8.3 STX, ENQ
- A.8.4 ENQ

B BILL OF MATERIALS

C SCHEMATICS

LIST OF ILLUSTRATIONS

<u>FIGURE NO.</u>	<u>TITLE</u>	<u>PAGE NO.</u>
2-1	MODEL 5528 COMMUNICATIONS CONTROLLER.....	2-4
2-2	MODEL 5528 COMMUNICATIONS CONTROLLER BACK PANEL.....	2-7
2-3	A TYPICAL BISYNCHRONOUS REMOTE CONNECTION.....	2-8
2-4	A TYPICAL BISYNCHRONOUS DIRECT CONNECTION.....	2-8
2-5	MODEL 5528 COMMUNICATIONS CONTROLLER FRONT PANEL.....	2-12
4-1	LINE MONITOR TEST.....	4-26
4-2	LINE MONITOR .....	4-27

LIST OF TABLES

<u>TABLE NO.</u>	<u>TITLE</u>	<u>PAGE</u>
2-1	MODEM OPERATIONS.....	2-14
2-2	SYNCHRONOUS BELL MODEMS.....	2-16
2-3	RS-232-C CONNECTOR PIN ASSIGNMENTS.....	2-17
3-1	WWPS DOCUMENT CODE SET Standard Version.....	3-42
3-2	WWPS INTERMEDIATE CODE SET Standard Version.....	3-43
3-3	IBM EBCDIC-DP CODE SET.....	3-44
3-4	EBCDIC-DP TO WWPS STANDARD/INTERMEDIATE CODE (code translation table).....	3-46
3-5	WWPS STANDARD/INTERMEDIATE CODE TO EBCDIC-DP (code translation table).....	3-47
4-1	CHARACTER CONVERSION.....	4-28

**1**

**INTRO-  
DUCTION**

## 1. INTRODUCTION

### 1.1. WORD PROCESSOR TELECOMMUNICATIONS

The telecommunications feature allow a Wang Word Processor to communicate with word processing and computer systems which use the most popular industry-standard Binary Synchronous Communications (BSC) conventions and procedures. These systems may be located either within the building where the Wang Word Processor resides or in distant places where telephone lines exist.

When telecommunications is used to exchange documents between word processor equipped offices, the capability is often called "electronic mail" or "electronic mailing" because completed documents can be sent from one office to another in minutes rather than days--no matter how great the distance between two offices. Until recently, electronic mail was only a prediction or a promise for the "office of the future"; now, however, electronic mail is becoming a reality in more and more of today's offices. Using telecommunications, document delivery time can be reduced as dramatically as the time from a first draft to a final document can be reduced using the document creation and editing features of a Wang Word Processor. During document transmission, words move over telephone lines at a speeds far exceeding the speed of words in voice communications. Large documents or information files (up to 4000 pages on a Word Processor 30 disk) can be sent to or received from remote sites at speeds as high as 25 pages per minute, in cases where the line speed is 9600 bps (bits per second).

On the other hand, when telecommunications is used to exchange documents between a Wang Word Processor and a computer system, the word processor eliminates the need for a Remote Job Entry (RJE) terminal. Files created and edited as documents on a Wang Word Processor can be transmitted to a host computer; also, files from a host computer can be "spooled" to the word processor system disk, where they are automatically stored as documents for subsequent

printing or editing. Documents sent to or received from a computer may contain information such as the following: (1) Job Control Language (JCL) files, (2) unformatted data files, and (3) source code files in computer languages, e.g., COBOL, BASIC, FORTRAN, PL1, and others.

If asked to think of the kinds of documents which might be transmitted from a business, professional, or government office (or a large word processing center), one tends to think first of letters, memoranda, legal papers, news bulletins, and other types of documents traditionally associated with offices where typing and secretarial services are required. Soon, however, computer-related documents may seem as commonplace as traditional office documents, especially in offices where communicating word processors are used in a dual capacity as word processors and computer terminals.

#### 1.2 THE BINARY SYNCHRONOUS COMMUNICATIONS OPTION

There is a Binary Synchronous Communication Option available for Wang Processors. This option is available as a combined hardware and software package and is identified as follows:

<u>Option</u>	<u>Type</u>
Model 5595-5	Bisynchronous Communications

The hardware consists of the Model 5528 Communications Controller and the software is available on a special utility diskette called the COM Diskette.

The Model 5528 Communications Controller, in conjunction with Wang's BSC 2780/3780 software package, adds Binary Synchronous Communications (BSC) capabilities to any Wang Word Processor. With the controller, the software, and a suitable modem, a Word Processor equipped office can communicate (exchange documents and text) with comparably equipped offices or with host computer system - while

concurrently performing all local word processing functions such as document editing, creation, and printing. With BSC capabilities, a Wang Word Processor can perform "electronic mailing" functions in addition to all its standard functions.

A Wang Word Processor can serve as a remote batch workstation to any host computer system supporting IBM 2780 or 3780 emulation, without requiring changes to existing host software. Also, the Word Processor can communicate with minicomputers, intelligent terminals, remote batch terminals, or non-Wang word processors - if these devices customarily use the industry standard 2780 or 3780 conventions, and the remote site's modem matches the characteristics of the modem connected to the Wang communications controller. When communicating with other Wang Word Processors, all internal codes are automatically transmitted.

Wang BSC 2780/3780 software supports point-to-point communications over leased or switched (dial-up) networks using any RS-232-C, CCITT V.24 compatible synchronous modem which provides clocking signals at up to 9600 bits per second. All standard and optional BSC features, including multi-record blocking, cyclic redundancy checks (CRC), extended transmission retry, data compression (3780 only) EBCDIC coded transmission, and transparent transmission are supported.

With the bisynchronous communications option, the model 5528 Communications Controller is connected to the word processor master unit by a coaxial cable in the same manner as any other workstation or printer. Usually, a synchronous type modem (not supplied with the controller) is attached to the communications controller and a telephone line; however, for special applications, direct connection to a site within the same building may be appropriate. When the communications software is added to the system disk, any workstation (or several workstations) may be used to schedule communications sessions--in a manner similar to initiating document printing. Each scheduled session represents a desired communications link between the

Wang Word Processor and a particular remote site; as many as six documents can be specified by their ID numbers when scheduling a session. A session queue (similar to a printer queue) is monitored by the communications controller, and the operator-assigned priorities are honored automatically. Furthermore, during document transmission or reception, all workstation and printer activities continue without interruption.



**2**

**INSTAL-  
LATION**

## 2. INSTALLATION

### 2.1 PRE-INSTALLATION PROCEDURES

Telecommunications system installation can be simplified a great deal if the few simple steps given below are observed:

- 1) If the customer requires a modem, check with Customer/Marketing representatives to ensure that the customer has ordered the right modem and options (refer to modem requirements in table 2.1) from a local telephone company or a private vendor.

NOTE:

Modem at local and at remote location must be of same type and compatible.

- 2) If the customer has ordered the proper modem then plan the TC installation the same day the modem is being installed. If modem installer is still present, make sure you check out the system in his presence because he can help you identify modem or telephone line problems.
- 3) If applicable, obtain the correct sign-on procedure and telephone number from the customer and verify it by calling data processing manager in charge at the remote computer location. Important: Also verify that the remote computer does support the emulation program your customer is going to use.

## 2.2 System Requirements

The minimum system requirements to provide a Wang Word Processing System, either a Editing Station, WP10A, WP20, or WP30, with Binary Synchronous Communications (BSC) capabilities are the following items:

### For modem connection:

1. A Model 5528 Communications Controller (W.L. #177-9303)
2. A COM diskette (contains BSC software)
  - A) COM 10A/20 diskette for use with either a Editing Station, W010A, or WP20.
  - B) COM 30 diskette use with a WP30.
3. A 12-foot, 25-pin RS-232-C compatible telecommunications cable (W.L. #220-0113).
4. 25-foot dual coaxial cable (W.L. #220-0148).
5. Modem.
6. For a WP10A only, a 3 port BNC/TNC connector panel (W.L. #270-0368).
7. For a Editing Station only, a 2 port BNC/TNC connector panel (W.L. #270-0339)
8. Some customers may require a workstation equipped with the Horizontal Scroll Option if they will be communicating with Host Computers that transmit records (print lines) that contain more than 80 characters.

### For direct/local connection:

1. All of the above items except for the modem.
2. A Model 2228N Null Modem (W.L. #177-2228N).

3. Another A 12-foot, 25-pin RS-232-C compatible telecommunications cable (W.L. #220-0113).

## 2.3 INSTALLATION PROCEDURES

### 2.3.1 SITE SELECTION:

When selecting a site for a Model 5528 Communication Controller, it is very important that it should be located close to the modem location so that a 12 foot TC cable can reach the modem.

It is not required or necessary to have the Model 5528 near the Master CPU because, as with other 928 workstations or printers, it can be up to 2000 feet from the Master CPU. The customer should be aware of this and must order appropriate length co-ax cable for the Model 5528 (25 feet coax is standard).

A 110V (220V) power outlet must be available for the Model 5528 as well as the modem at the installation site.

### 2.3.2 D.C. VOLTAGE ADJUSTMENTS ON REGULATOR BOARD

Before operating the Model 5528, D.C. regulated voltages must be checked or adjusted as required. Refer to figure 2.1 for pot locations on the 7358 regulator board for various regulated voltages.

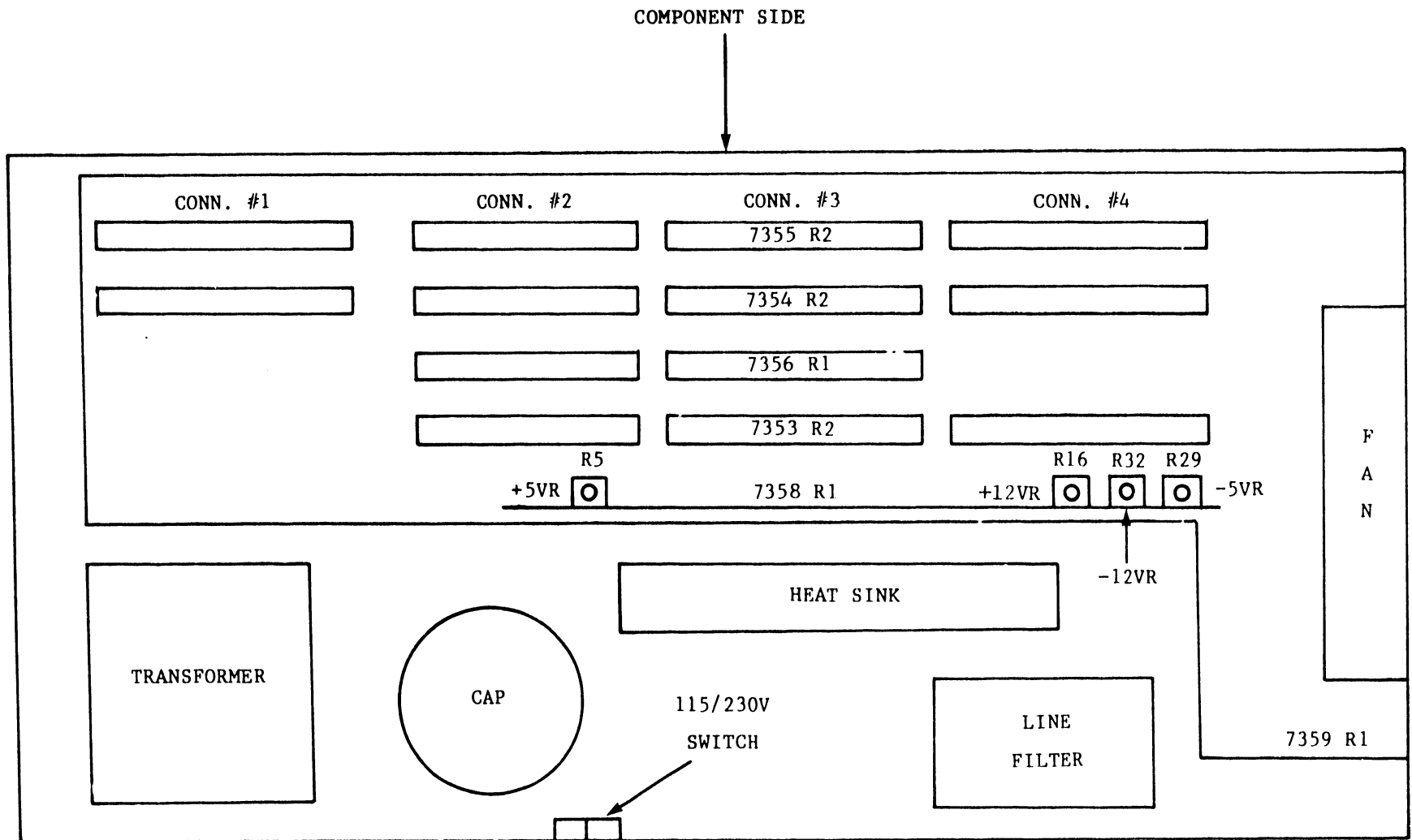


FIGURE 2.1 MODEL 5528 COMMUNICATIONS CONTROLLER

ADJUST POT ON 7358 PCB	REGULATED VOLTAGE	LOCATION	ADJUSTED VOLTAGE RANGE
R5	+ 5 Volts	7355 PCB Pin Y, Conn.4	+ 4.9 to + 5.1
R16	+12 Volts	7355 PCB Pin S, Conn. 2	+11.75 to +12.25
R29	- 5 Volts	7355 PCB Pin X, Conn. 4	- 4.9. to - 5.1
R32	-12 Volts	7356 PCB Pin 14, Conn. 2	-11.75 to -12.25

OR

L4 (75150 IC) Pin 5

### 2.3.3. ADDRESS SWITCH SETTINGS

PCB 7353 has a bank of five Device Type microswitches to be set as specified that a Model 5528 is connected to the Master CPU (Device Type = HEX 08).

	1	2	3	4	5
ON	*	*	*	*	
OFF					*

The Model 5528 hardware also has a facility to have more than one Model 5528 connected to the Master CPU. In this case, each TC Channel must have its unique address set by the bank of 8 Channel I.D. microswitches on PCB 7355. At this time, only one Model 5528 can be attached to the WP system so only address switch No. 1 must be set to "ON".

### 2.3.4 INSTALLATION:

- 1) Connect the Model 5528 to one of the available channels on the rear of the Master CPU by a coaxial cable. (Check the cable for defects and perform continuity check.)

2) For Modem Connection:

- A) Connect the supplied TC cable; one end to the Model 5528 RS-232-C connector labeled "MODEM", and the other end to the modem connector labeled "Customer Equipment" (Refer to Figures 2.2 and 2.3).
  
- B) Connect the modem and Model 5528 to a power outlet and turn both power switches on.

For Direct/Local Connection:

- A) Connect one of the supplied TC cables; one end to the Model 5528 RS-232-C connector labeled "MODEM" and the other end to the connector of the 2228N Null Modem closest to the label reading "2228N" - (Refer to Figures 2.2 and 2.4)

NOTE:

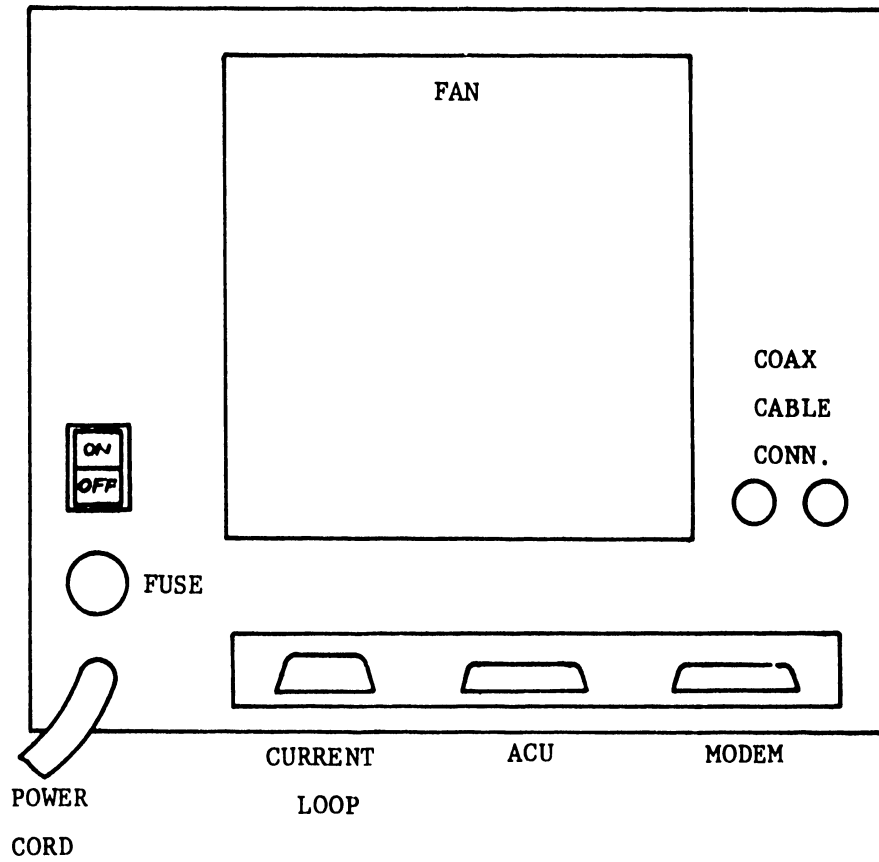
It is extremely important that the 2228N Null Modem be connected in this fashion as this device has definite polarity and will not operate any other way.

- B) Connect the other TC cable supplied; one end to the other side of the 2228N, and the other end to other systems RS-232-C port.
  
- C) Connect the Model 5528 to a power outlet and turn the power switch on.

- 3) Perform on-line TC diagnostic tests if available (refer to section 4.1) or perform on-line check (refer to section 4.2)

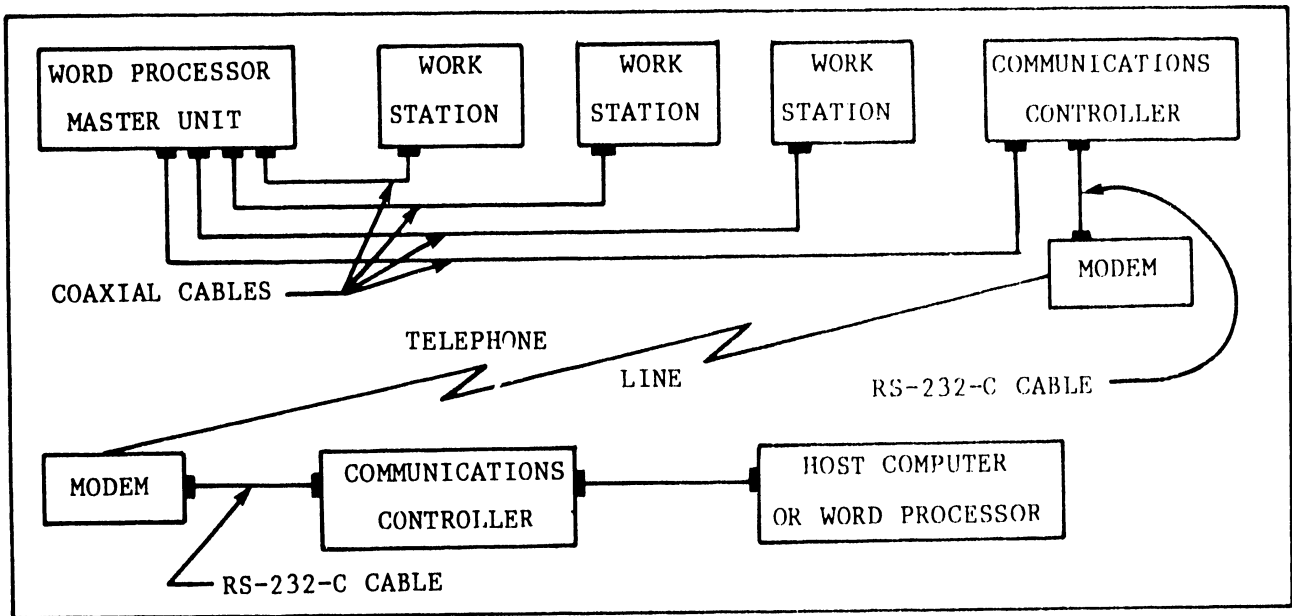
NOTE:

It is necessary to have 7214 or 7214-1 board in Master CPU for Model 5528 to function.

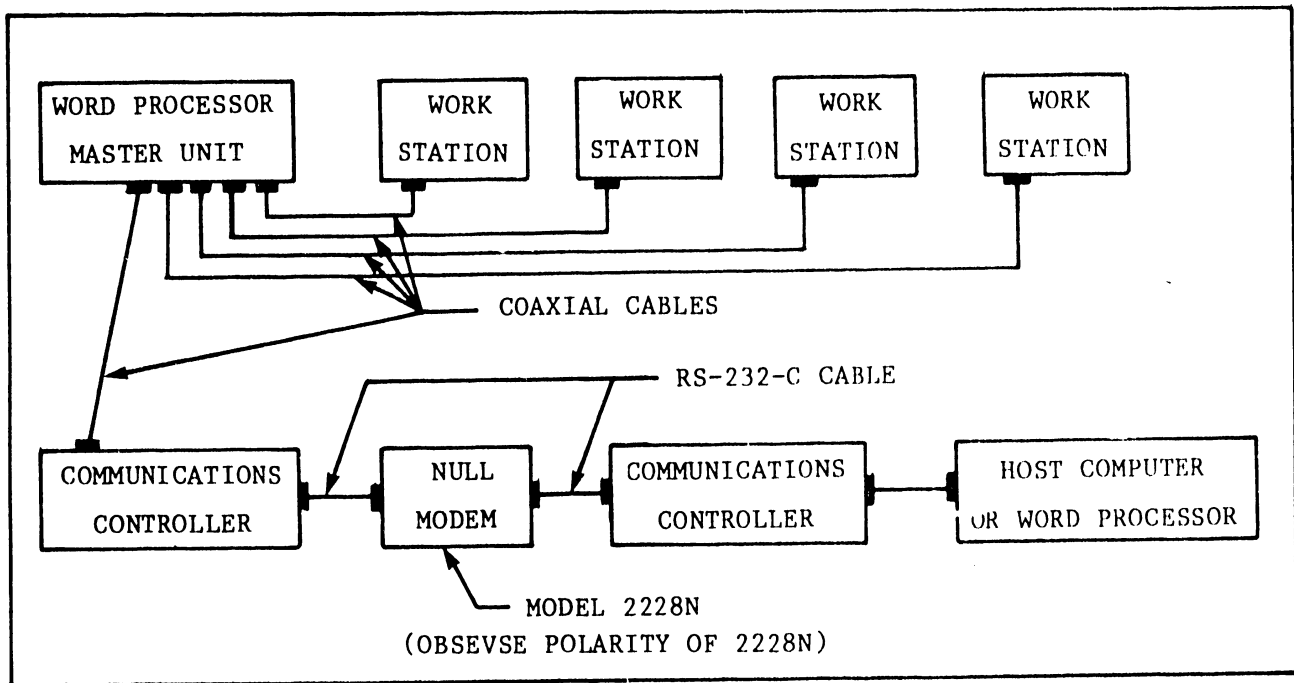


**FIGURE 2.2 MODEL 5528 COMMUNICATIONS CONTROLLER BACK PANEL**





**FIGURE 2.3 A TYPICAL BISYNCHRONOUS REMOTE CONNECTION**



**FIGURE 2.4 A TYPICAL BISYNCHRONOUS DIRECT CONNECTION**

The pin assignments are listed in Table 2.3 with both the EIA and the CCITT designations given for the circuit associated with each pin. Also, the signal descriptions and sources are included in the table.

#### 2.4 MODEL 5528 COMMUNICATIONS CONTROLLER SPECIFICATIONS

TC Processor channel Model No. 5528 (W.L. #177-9303)

P.C. Board Numbers:

210-7353	Data Link TC
210-7354	Memory
210-7355	CPU
210-7356	Modem/ACU Interface (RS-232)
210-7357	TCP Current Loop (replaces 7356 PCB)
210-7358	Voltage Regulator
210-7359	Motherboard (Chassis)

Height

8" (22 cm)

Width

9" (23 cm)

Depth

19" (48 cm)

Voltage

110V (220V) - switch selectable

Power

150 watts

Fuse Rating

1.5A (115V)/3A (230V)

## 2.5 MODEM REQUIREMENTS

The modem, or dataset, used with the system may be rented from the telephone company or purchased from any one of several modem vendors. In either case, the telephone company must connect the modem to the telephone network via telephone company installed data access arrangement (DAA). The DAA consists of a telephone handset and a modem interface rented from the telephone company. Usually a modem or DAA is permanently wired to a wall; therefore, it should be installed as close as possible to the Wang Word Processing system.

### NOTE:

Ordering of a modem for a Wang customer is not the responsibility of a Wang Salesman nor is the installation of a modem the responsibility of a Wang Customer Engineer. Refer to table 2.1 for a list of the options that must be selected for each modem.

The modems used at both ends of a communications line must be compatible. For example, if a BELL 201C type modem is used at one end, another BELL 201C or equivalent must be used at the other end (not a 201A, 208B, 202C, or 202S). The modems listed in Table 2.2 or their equivalents may be used.

The controller conforms to the nationally recognized EIA RS-232-C and the internationally recognized CCITT V.24 standards for voltage levels and pin connections (refer to PRODUCT SERVICE TELEPROCESSING GUIDE, page 76). The signal polarity and the voltage of driven and detected signals are as follows:

<u>Logic Level</u>	<u>Applied Voltage</u>	<u>Detected Voltage</u>
0 or ON (Spacing)	+8 vdc	+3 to +25 vdc
1 or OFF (Marking)	-8 vdc	-3 to -25 vdc

#### Four I/O Connectors

- 1) Modem (RS-232-C)
- +2) Automatic Calling Unit (ACU)
- +3) Current loop
- 4) Datalink coax connector.

#### Status lamps

- 1) Data set ready (DSR)
- \*2) Communications in progress (BUSY)
- \*3) Power ON

#### Switch

One data communication mode, disconnect switch

#### Cables

- 1) A 25 foot dual co-ax cable (Part #220-0148)
- 2) A 12 foot 25 pin TC cable (Part #220-0113) supplied with the system

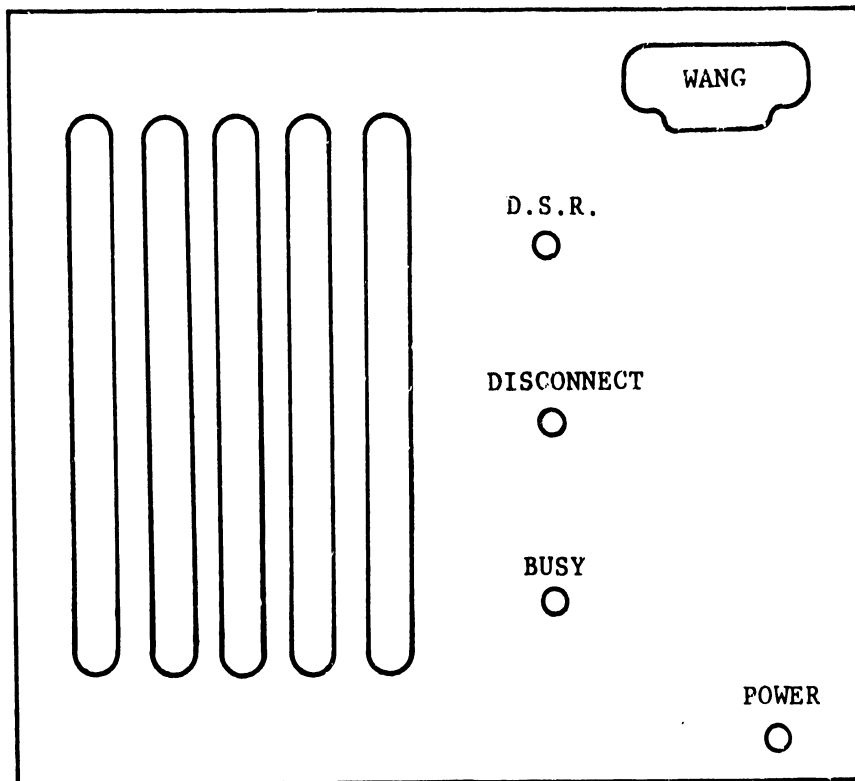
+Feature not available at this publication writing.

\*Not available on initial deliveries.

## 2.6 MODEL 5528 COMMUNICATIONS CONTROLLER FRONT PANEL INDICATORS

The front panel of the Model 5528 Communications Controller contains three LED indicators and one push button switch (refer to figure 2.5). The purpose of these items is as follows:

D.S.R.: This LED indicates the state of the modem interface signal Data Set Ready (D.S.R.) at the RS-232-C connector. When the LED is ON, this represents the ON (active) state of the D.S.R. signal. This signal MUST be ON in order for data to be transferred over the communications line.



**FIGURE 2.5 MODEL 5528 COMMUNICATIONS  
CONTROLLER FRONT PANEL**

**BUSY:** The ON condition of this LED indicates that the 5528 Communications Controller is either transmitting or receiving data over the communications line.

**POWER:** The ON condition of this LED indicates the the 5528 Communications Controller is power-ed on.

**DISCONNECT:** This switch, when depressed, will disconnect a modem from the telephone lines. After the telephone line is dropped, the D.S.R. led will turn OFF indicating the disconnection has been completed.

TABLE 2-1  
MODEM OPTIONS

Bell Modem or Equivalent  
201A

Options

transmitter internally timed

EIA interface

with/without permanent  
unattended answer

with/without automatic  
calling \*

half-duplex operation

carrier controlled by  
request to send

without New Sync

201B

all the options listed for  
the 201A with the  
exceptions:

with/without alternate voice

half/full - duplex operation

continuous - carrier or  
carrier controlled by  
Request to send.

---

\* At present time, Automatic Calling Unit (ACU) is not available.

TABLE 2-1 (CONTINUED)

201C

For use with the switched  
telephone network:

all the options listed for  
the 201A

For use with private or  
leased lines:

all the options listed for  
the 201B

Request-to-Send  
Clear-to-Send delay of  
150/7/0 msec

208A

all the options listed for  
the 201B

Data Set Ready ON when AL  
test button is pressed

with/without one second  
holdover at receiver on  
line dropouts

208B

all the options listed for  
201A

Data Set Ready ON when AL  
test button is pressed



TABLE 2-2  
 SYNCHRONOUS BELL MODEMS

<u>BELL MODEM</u>	<u>SPEED (BAUD)</u>	<u>DESCRIPTION</u>
201A	2000	- obsolete - half-duplex (switched telephone network)
201B	2400	- half/full-duplex (private or leased lines)
201C	2400	- half-duplex (switched telephone network) - half/full - duplex (private or leased lines)
208A	4800	- half/full - duplex (private or leased lines)
208B	4800	- half - duplex (switched telephone network)
212A	1200	- full - duplex (switched telephone network) - this modem can also operate asynchronously

TABLE 2-3  
RS-232-C CONNECTOR PIN ASSIGNMENTS

<u>PIN</u>	<u>EIA</u>	<u>CCITT</u>	<u>SIGNAL DESCRIPTION</u>	<u>SOURCE</u>
1	AA	101	Protective Ground	
2	BA	103	Transmitted Data	Controller
3	BB	104	Received Data	Modem
4	CA	105	Request to Send	Controller
5	CB	106	Clear to Send	Modem
6	CC	107	Data Set Ready	Modem
7	AB	102	Signal Ground	
8	CF	109	Received line Signal Detector	Modem
9*				
10*				
11	SCA	120	Secondary Request to Send	Controller
12	SCF	122	Secondary Rec'd Line Sig. Det.	Modem
13*	SCB	121	Secondary Clear to Send	Modem
14*	SBA	118	Secondary Transmitted Data	Controller
15	DB	114	Trans. Signal Element Timing	Modem
16*	SBB	119	Secondary Received Data	Modem
17	DD	115	Receiver Signal Element Timing	Modem
18*		124	Select Frequency Groups	Controller
19	SCA	120	Secondary Request to Send	Controller
20	CD	108.2	Data Terminal Ready	Controller
21*	CG	110	Signal Quality Detector	Modem
22*	CE	125	Ring Indicator	Modem
23*	CH/CI	111/112	Data Signalling Rate Selector	Controller/ Modem
24*	DA	113	Trans. Signal Element Timing	Controller
25*			Unassigned	

---

\*Denotes signals not used by the Model 5528.

**3**

**BINARY  
SYNCHRONOUS  
COMMUNICATIONS  
SOFTWARE**

### 3. BINARY SYNCHRONOUS SOFTWARE

#### 3.1 2780/3780 EMULATION DESCRIPTION AND SPECIFICATIONS

The IBM 2780 and 3780 data communication terminals are stand alone devices used for remote data entry and retrieval. They allow the user to send large batches of IBM card image data and receive print or punch data in return over a telecommunications line utilizing IBM's Binary Synchronous Communication (BSC) procedure. The BSC procedure provides a set of rules for the efficient, orderly transmission of binary-coded data at line speeds up to 9600 bps.

Wang's 2780/3780 communications emulation software allows a Wang Word Processing System to communicate using the 2780/3780 protocol. By use of the emulator, a Wang Word Processing System can communicate with any system supporting this protocol including an IBM 2780 or 3780 terminal, a host computer supporting 2780 or 3780 devices, another Wang System with a 2780/3780 emulator (either a 2200 System or Word Processing System), or any other device using the 2780/3780 protocol.

The Wang 2780/3780 emulation software used for the Word Processing System offers many features not available on a standard IBM 2780 or 3780. Transmission of files (in the form of documents) to and from the system disk/diskette is automatic, thus allowing the system to send/receive document text data, unformatted data files, and source code files in computer languages (e.g., COBOL, BASIC, FORTRAN, PL1). Local data entry directly to the system disk in the form of a document eliminates the need for keypunching. Data received by the system can be queued to a printer later to provide a hard copy.

#### SPECIFICATION:

Emulation:                   2780/3780 Emulation.

Package No.:                Option 5595-5 (hardware and BSC software).

Line Discipline: BSC point-to-point operation on a dial-up or leased private line (half-duplex).

Line Speeds: Up to 9600 bits per second.

Connection: A Wang 2228N null-modem may be used for local connections via an RS 232-C interface for distances up to 100 feet at 9600 bps.

Using Short Haul modem and private lines, connection of up to 5 miles can be made.

For longer distances, Bell or equivalent type modems may be used on common carrier telephone lines. Refer to table 2.2 for a list of Bell modems.

Controller: Model 5528 Communications Controller.

Systems: Editing Station, WP10A, WP20, and WP30.

Code Translation: Reception - from EBCDIC line code to modified ASCII in non-transparent or transparent mode (no code translation takes place between two Wang Word Processing Systems).

Transmission - from modified ASCII to EBCDIC line code in non-transparent or transparent mode (no code translation takes place between two Wang Word Processing Systems).

Error Detection: CRC block checking.

Record Length: Reception - variable (up to 249 bytes including data link control characters).

Transmission - 80 bytes (may be less than 80 bytes when using 3780 emulation with space compression feature).

Block Size: Up to 400 bytes on 2780 and 512 bytes on 3780 (both including data link control characters.

Record Blocking: Single or Multi-record blocking.  
Default is multi-record blocking.

Communicates with: -Any host computer system supporting IBM 2780/3780.  
-Another IBM 2780/3780-like device.  
-Another Wang system with 2780/3780 emulation.

Modes of Operation: Send non-transparent mode (document from disk).  
Send transparent mode (document from disk).  
Receive non-transparent mode (document to disk).  
Receive transparent mode (document to disk).

Transmit From: System disk.

Receive To: System disk.

3780 Emulation: With or without space compression.

## 3.2 TC RELEASE 15.3T4 and 5.3T4

### 3.2.1 INTRODUCTION

This release contains Binary Synchronous (Bisync) TC, Asynchronous (Async) TC, and Optical Character Recognition (OCR) software on the COM disk. The TC Function Selection allows the user to select the discipline(s) that are to be used at installation. The

WPS, 2780, 2780v, 3780, and 3780c disciplines use Bisync software and require a model 5528 TC processor while the TTY and 2741 disciplines are use Async software and require a TC Workstation. The model 5528 TC processor is also required for OCR operation.

### 3.2.2 NULL MODEM LINE SPEEDS

The default line speed for directly connected BSC operation using the Communications Controller with a 2228N Null Modem is 2400 bps. If higher speeds are desired the COM 10A/20/30 disk may be changed by SZAP as follows:

<u>Speed</u>	<u>Track</u>	<u>Sector</u>	<u>Byte</u>	<u>Old Value</u>	<u>New Value</u>
4800 bps	34	09	F7	01	80
9600 bps	34	09	F7	01	C0

### 3.2.3 RECORD BLOCKING

The 2780/3780 emulators default to multiple record blocking. If single record blocking is required then the COM Diskette may be changed by SZAP as follows:

<u>Connection</u>	<u>Track</u>	<u>Sector</u>	<u>Byte</u>	<u>Old Value</u>	<u>New Value</u>
2780	34	0C	5E	B0	90
3780	34	0C	D6	B0	90
3780C	34	0C	9A	F0	D0

### 3.2.4 TIMEOUT LOGIC

The BSC software provides for two separate timeouts, a short timeout and a long timeout. The short timeout provides the time delay between the transmission of a sign-on document and the next document to be transmitted (refer to section 3.5.1) and is also the time delay before a session will enter its period of inactivity (refer to section 3.5.3). The default short timeout is for 23 seconds. The long timeout is the timeout the causes the active session to terminate and

disconnect the telephone after a specified time of inactivity. After the timeout runs down, a disconnect sequence code for a switched telephone line (DLE EOT) is automatically transmitted to the remote end to disconnect the telephone connection at both ends. The default long timeout is forever (disabled).

To change the default settings, the Session Control Block (SCB) Initial located on the COM disk may be changed by SZAP as follows:

<u>TIMEOUT</u>	<u>TRACK</u>	<u>SECTOR</u>	<u>BYTE</u>	<u>OLD VALUE</u>
short	35	0D	A0-A1	1700 (23 seconds)
long	35	0D	A2-A3	FFFF (disabled)

To calculate the new value for either timeout (two bytes), take the desired timeout value in seconds and convert it from a decimal number to a two byte hexadecimal number and then transpose the two bytes. As an example, set a timeout for 30 seconds. 30 in decimal equals '001E' as a two byte hexadecimal number and then transposing the two bytes the final value is '1E00'.

NOTE:

Any timeout value set over 32K seconds (high order bit is set) will disable that timeout.

### 3.2.5 SPECIAL TRANSMIT CHARACTERS

It is possible for the 2780/3780 emulators, during send, to distinguish between underlined and non-underlined characters by changing the WWPS/EBCDIC Translation Table (table 3.5) by SZAP. The WWPS/EBCDIC Translation Table is located on the COM disk on track 31, sector 0E (refer to table 3.5). The default setting is to convert underlined characters to non-underlined characters. By changing the translation table, special EBCDIC hex codes can be transmitted by using underline characters in the document text. For example, if it



is desired to transmit a hex'DD' in EBCDIC, first select the underlined character, such as "X", to represent this EBCDIC code. In the modified WWPS code set (table 3.1), the "X" is a hex'D8' value. Go to the translation table and change byte D8 from hex'E7' to hex'DD'. Now, when the character "X" is transmitted in the document text, a EBCDIC hex'DD' will be transmitted instead of hex'E7'. Refer to table 3.3 for the EBCDIC code set.

### 3.3 PROCEDURE FOR LOADING COMMUNICATIONS ONTO A EDITING STATION/WP10A/WP20

Three disks are involved in preparing for communications on a Editing Station, WP10A, or WP20: a Utility Disk (currently 15.4/4.4), a blank new disk which will become the System Disk with Communications, and Communications Master Disk called COM 10A/20 (currently 15.3T4).

#### NOTE:

The COM 10A/20 Release 15.3T4 can be used with all Word Processing Software Releases 15.1 and above Editing Station or WP20 and 4.1 and above on WP10A.

1. Archive all documents. Make note of next available DOCUMENT and FLOPPY ID numbers. Remove both old System and Archive disks. Place a blank new disk with a write tab in the left (Archive) drive, and depressing the indented RESET button on the Master Unit.
2. Select "CREATE SYSTEM DISK-IN'TIAL IDS & FORMAT" by moving the cursor with the space bar, and then keying Execute twice (this operation will take approximately 1 minute).

NOTE: Do not use "CREATE SYSTEM DISK - OLD IDS & FORMAT"

3. Leave the newly created system disk in the left drive. Select "CHANGE IDS & STANDARD FORMAT". Follow menu instructions inputting document and floppy ID's noted in step 1.

4. Remove the Utility Disk from the right drive.
5. Load the COM 10A/20 Disk by placing it in the right (System Drive, and depressing the indented RESET button on the Master Unit.

NOTE: THE COM 10A/20 DISK WILL NOT LOAD UNLESS IT HAS A WRITE TAB ON IT.

6. Fill in the date and time on the start-up menu. The first set-up menu will now appear as shown below:

- Network Editing
- TC Function Selection
- TC System Updating
- OCR System Updating
- Other Functions

"Network Editing" is not available for this release.

"TC Function Selection" allows the user to select the desired discipline(s) which will be later transferred from the COM Disk to the System Disk by "TC System Updating".

"TC System Updating" allows the user to load the software for the selected discipline(s) onto the System Disk.

"OCR System Updating" allows the user to load the OCR software onto the Systems Disk.

"Other Functions" allows the user to access SZAP from the COM disk (enter 1776! as the authorized code)

7. Select the "TC Function Selection" by moving the cursor with the space bar and then keying Execute. Another menu will appear as shown:

Please Select up to 3 functions:

	1	2	3
None	.	.	.
TTY Emulation	.	.	.
2741 Emulation	.	.	.
WPS/2780 Emulation	.	.	.
WPS/3780 Emulation	.	.	.
WPS/Send to 2780/3780	.	.	.

"TTY Emulation" selects software for Teletype emulation.

"2741 Emulation" selects software for 2741 emulation.

"WPS/2780 Emulation" selects software for 2780 emulation and WPS-to-WPS connection.

"WPS/3780 Emulation" selects software for 3780 emulation and WPS-to-WPS connection.

"WPS/Send to 2780/3780" selects software for transmitting to a 2780/3780 terminal and WPS-to-WPS connection.

8. To select and different discipline(s), use the space bar to position the cursor along side the desired discipline. The Return key allows the user to move to a different column to select another discipline. Up to three different selections may be picked. After the selections are made, key Execute to store the selections. The system will return to the set-up menu of step 6.

9. Select "TC system Updating". the following menu will be displayed:

- Copy Network and Software to System Disk
- Update Network on System Disk
- Update Network on Communications Disk

"Copy Network and Software to System Disk" copies the selected communications software onto the System Disk.

"Update Network on System Disk" updates the selected communications network (connection) on the System Disk. Do Not Use.

"Update Network on Communications Disk" updates the communications network (connection) on the COM Disk. Do Not Use.

10. Select the first choice "Copy Network and Software to System Disk" by keying Execute.

11. A prompt appears as follows:

Insert Communications Disk in System Drive

Insert System Disk in Archive Drive

(This is how the disk should already be positioned at this point if the instructions have been followed correctly. The COM 10A/20 disk should be in the right (System) drive and the newly created system Disk should be in the left (Archive) drive.

12. If the disks are positioned properly then key Execute. The movement of the Communications software onto the new System Disk should take less than one minute.

13. The Editing Station/WP10A/WP20 System Disk in the left drive now contains communications software. Remove it and label it "System Disk 15.4/4.4 with BSC COM 15.3T4.

14. The new system Disk with COM may now be placed in the right (System) drive, and the system can be initialized by depressing the indented RESET button on the Master.

NOTE:

The Communications Software takes up some of the available document space on the System Disk, and thus the "disk space message" at the bottom of the main menu will state that the disk is 23% to 28% full with 0 documents depending on the discipline(s) selected.

15. Refer to 2780/3780 TC OPERATING INSTRUCTIONS in section 3.5 for operational procedures concerning the Communication Feature.

### 3.4 PROCEDURE FOR LOADING COMMUNICATIONS ONTO A WP30

Two disks are involved in preparing for communications on a WP 30: a Utility Disk (currently 5.4), and a Communications Master Disk called COM 30 (currently 5.3T4).

NOTE:

The COM 30 Release 5.3T4 can be used with all Word Processing Software Releases 5.1 and above.

1. ARCHIVE ALL DOCUMENTS. This is imperative as this procedure involves initializing the System Disk. It is the customer's responsibility to archive all documents of value. Make note of next available DOCUMENT and FLOPPY ID numbers. Remove any Archive disks in the Archive Drive. Load the Utility Disk by placing it in the Archive drive, moving the indented Utility Load Toggle Switch (located in the air vents on the front of the Master) to the UP position, and depressing the indented RESET button on the Master Unit.
2. Select "INITIALIZE SYSTEM DISK" by moving the cursor with the space bar, and then keying Execute twice (this operation will take a few minutes).
3. Select "CHANGE IDS & STANDARD FORMAT". Follow menu instructions inputting document and floppy ID's noted in step 1.

4. Remove the Utility Disk from the Archive drive.
5. Load the COM 30 Disk by placing it in the Archive drive, check that the indented Utility Load Toggle Switch is still up, and depress the indented RESET button on the Master Unit.

NOTE: THE COM 30 DISK WILL NOT LOAD UNLESS IT HAS A WRITE TAB ON IT.

6. Fill in the date and time on the start-up menu. The first set-up menu will now appear as shown below:

- Network Editing
- TC Function Selection
- TC System Updating
- OCR System Updating
- Other Functions

"Network Editing" is not available for this release.

"TC Function Selection" allows the user to select the desired discipline(s) which will be later transferred from the COM Disk to the System Disk by "TC System Updating".

"TC System Updating" allows the user to load the software for the selected discipline(s) onto the System Disk.

"OCR System Updating" allows the user to load the OCR software onto the System Disk.

"Other Functions" allows the user to access SZAP from the COM disk (enter 1776! as the authorized code)

7. Select the "TC Function Selection" by moving the cursor with the space bar and then keying Execute. Another menu will appear as shown:

Please Select up to 3 Functions:

None	.	.	.
TTY Emulation	.	.	.
2741 Emulation	.	.	.
WPS/2780 Emulation	.	.	.
WPS/3780 Emulation	.	.	.
WPS/Send to 2780/3780	.	.	.

"TTY Emulation" selects software for Teletype emulation.

"2741 Emulation" selects software for 2741 emulation.

"WPS/2780 Emulation" selects software for 2780 emulation and WPS-to-WPS connection.

"WPS/3780 Emulation" selects software for 3780 emulation and WPS-to-WPS connection.

"WPS/Send to 2780/3780" selects software for transmitting to a 2780/3780 terminal and WPS-to-WPS connection.

8. to select the different discipline(s), use the space bar to position the cursor along side the desired discipline. The Return key allows the user to move to a different column to select another discipline. Up to three different selections may be picked. After the selections are made, key Execute to store the selections. The system will return to the set-up menu of step 6.

9. Select "TC System Updating". The following menu will be displayed:

- Copy Network and Software to System Disk
- Update Network on System Disk
- Update Network on Communications Disk

"Copy Network and Software to System Disk" copies the selected communications software onto the System Disk.

Update Network on System Disk" updates the selected communications network (connection) on the System Disk. Do Not Use.

Update Network on Communication Disk" updates the communications network (connection) on the COM Disk. Do Not Use.

10. Select the first choice "Copy Network and Software to System Disk" by keying Execute.

11. A prompt appears as follows:

Insert Communications Disk in Archive Drive.

(this is where the COM 30 disk should already be positioned at this point if the instructions have been followed correctly.)

12. If the disk is positioned properly then key Execute. The movement of the Communication software onto the initialized System Disk should take less than one minute.

13. The WPS 30 System Disk is now updated with the latest release of the Word Processing Software (currently 5.4), and the latest Communications Software (currently 5.3T4).

14. The new System Disk with COM may now be initialized by moving the indented Utility Load Toggle Switch to the DOWN position, and depressing the indented RESET button on the Master Unit.

NOTE:

The Communications Software takes up some of the available document space on the System Disk, and thus the "disk space message" at the bottom of the main menu will state that the disk is 1% full with 0 documents.



15. At this point, the documents which has been archived can now be retrieved to the System Disk.

16. Refer to 2780/3780 TC OPERATING INSTRUCTIONS in section 3.5 for operational procedures concerning the Communication Feature.

### 3.5 BSC EMULATOR OPERATING INSTRUCTIONS

#### 3.5.1 PREPARING TO SEND OR RECEIVE DOCUMENTS

Successful communications with another site can be achieved if a few preliminary steps are taken before going on-line:

- 1) Make sure the Model 5528 Communications Controller's power switch is ON. This can be verified by observing the POWER light located on the lower right-hand corner of the 5528. Communications, like printing, occurs as a background activity, and as such there are no operator prompts to alert the user that unit's power is off.
- 2) Check that the scheduled connection will be compatible with the requirements of the other site. Some considerations are:
  - A) Choose the proper connection either WPS, 2780, 2780v, 3780, or 3780c, to match the line discipline used by the other end. Mismatches can cause unpredictable results.
  - B) Check that the other site supports the following operating parameters (refer to section 3.1)
    - half-duplex mode
    - line speeds up to 9600 bps
    - EBCDIC line code (non-WPS connection)
    - transparent or non-transparent data
    - transmitted record length of 80 bytes
    - variable received record length (up to 249 bytes)

- maximum block size of either 400 bytes for 2780  
or 512 bytes for 3780
  - either single or multi-record blocking (multi-record  
blocking is standard)
  - 3780 emulation with or without space compression
- C) If modems are used, ensure that the modems at both end of  
the connection are compatible types. Refer to Section 2.5
- 3) If used, verify the correct telephone number and sign-on  
procedure for the remote site.
- 4) Prepare the documents to be transmitted in advance keeping in  
mind that certain format restrictions may be imposed by the line  
connection.

There are no format restrictions for document communications to  
other Wang Word Processors using WPS connections. Usually,  
computer documents containing JCL, source code, or card image  
data should have an 80-character format line, and each "line" or  
"card image" should be terminated by keying RETURN in position 80  
or less. However, since each line is sent as a card image  
whether terminated by a RETURN code or not, text documents for  
2780, 3780, or 3780c connections need no special editing if an  
80-character (or less) format line is used. If longer format  
lines are used with the horizontal scroll option, the document  
should be sent in transparent mode if the host computer supports  
this alternative. If these documents are sent in non-transparent  
mode, all the characters from the 81st position on will NOT be  
sent (refer to section 3.9.5).

- 5) A sign-on document should have a slash followed by an asterisk in  
the comments line of the document summary as illustrated here:

DOCUMENT SUMMARY

Document ID: 0010B  
Document Name: Sign-on Card Image  
Operator: PW  
Author: ESW  
  
Comments: /\*

If /\* appears in the comments line, a time delay automatically follows transmission of the document to allow host verification of the required sign-on information, thereby ensuring against loss of subsequent transmission from the Wang Word Processor. A typical sign-on document contains only one line of text in precise positions within the line, as illustrated here:

/*SIGNON	REMOTE 62	ABCPQXYZ
!	!	!
Position 1	Position 16	Position 28

If the sign-on document is incorrect, the host will generally send no response and will sometimes drop the line connection.

- 6) Any document to be sent in transparent mode during a 2780, 3780, or 3780c connection to a host computer) should have two slashes in the comment lines as follows:

DOCUMENT SUMMARY

Document ID: 0093G  
Document Name: Status Report JMS-58  
Operator: Pw  
Author: J. M. Snow  
  
Comments: //

In transparent mode, all internal Wang Word Processor codes are transmitted, including format lines and screen graphics; however, adjustments to the host computer software may be required if the host computer is to process the document. Documents received in the transparent mode will also have a // in the comments field.

- 7) When sending documents to a computer, a sign-on document is usually needed first; also, special JCL (Job Control Language) documents may need to go between other documents. This information must be furnished to an operator by the person responsible for coordinating communications with the remote facility.

### 3.5.2 SCHEDULING A TELECOMMUNICATIONS SESSION

The entire operating instructions for running a communications session consists of simply selecting the Telecommunications item on the WPS Main Menu, and then filling out three brief Menus which are specifically related to TC.

#### PROCEDURE:

1. Begin with the main menu--

#### WANG WORD PROCESSING SYSTEM

Please select next activity:

- . Edit Old Document
- . Create New Document
- . Print Document
- . Special Print Functions
- . Document Index
- . Document Filing
- \* Telecommunication
- . Other Functions

Select 'Telecommunications' and touch EXECUTE.

2. When the telecommunication menu appears--

Select Telecommunications Action

- \* Schedule a Telecommunication Session
- . Cancel a Telecommunication Session
- . Display Telecommunication Session Request
- . Display Telecommunication Session Summary
- . Display Telecommunication Connections

accept the default choice, as shown, and touch EXECUTE.

3. The following display now appears:

Schedule a Telecommunication Session

Session: 0003A

Connection:           .....

(An ID is supplied by the system; the cursor indicates an operator entry is required for the connection.)

The following connections are valid for Release 15.1T2 or 5.1T2 of the COM Disk:

<u>Connection</u>		
<u>Name</u>	<u>Restrictions</u>	<u>Purpose</u>
WPS	Requires bisynchronous hardware (Model 5528) and 2780 or 3780 emulation.	For connections to other Wang Word Processors--codes representing document format lines, screen graphics, IDs and authors' names are exchanged.

2780	Requires bisynchronous hardware (Model 5528) and 2780 emulation.	For connections to host computers or non-Wang word processors using the 2780 protocol.
2780v	Requires bisynchronous hardware (Model 5528) and Send to 2780/3780 software.	For connections to 2780 terminal.
3780	Requires bisynchronous hardware (Model 5528) and 3780 emulation.	For connections to host computers or non-Wang word processors using the 3780 protocol (without compression).
3780c	Requires bisynchronous hardware (Model 5528) and 3780 emulation.	Includes 3780 compression; otherwise, same as 3780 connections.
TTY	Requires asynchronous hardware and TTY emulation.	For connections to host computers or compatible terminals using the Teletype protocol.
2741t	Requires asynchronous hardware and 2741 emulation.	For connections to host computers using the IBM 2741 protocol.
2741h	Requires asynchronous hardware and 2741 emulation.	For connections to compatible terminals using the IBM 2741 protocol.

To determine which connections are possible, go to the telecommunications menu and select "Display Telecommunication Connections". A list of all the possible connections will be displayed even if they weren't selected.

CONNECTION SUMMARY

Connection ID	Channel/Class	Telephone Number	Discipline
WPS.....	1	.....	Electronic Mail
2780.....	1	.....	2780 Emulation
3780c....	1	.....	3780 Emulation
3780.....	1	.....	3780 Emulation
TTY.....		.....	TTY Emulation
2780v....	1	.....	2780 Emulation
274lh....		.....	
274lt....		.....	

Enter WPS, 2780, 2780v, 3780, or 3780c, depending upon which protocol is suitable for the remote facility--as illustration, the next step assumes that 2780 is the choice made here.

4. After a connection name is entered in step 3, the display expands-

Schedule a Telecommunication Session

```

Session: 0003A
Connection: 2780
....Baud 2780 EMULATION

DIAL.....
    
```

The heading, the session ID, and the operator entry from step 3 are repeated. Line speed in bps (baud) and a phone number are blank for Release 15.1T2 and 5.1T2

DOCID TRANSMIT DOCUMENT NAME

```

.....
.....
.....
.....
.....
.....
    
```

A blinking cursor indicates that a document ID can be entered now.

### Queue Session Request

- . at tail of queue
- . at head of queue
- . for \_\_\_ : \_\_\_

For a receive-only session, no document ID need be specified; touch EXECUTE and go to step 6. Otherwise, enter the first document ID. The corresponding document name is displayed for operator verification. If an incorrect document name is shown, position the cursor and enter the correct ID over the incorrect ID. Repeat the ID entry process until the last document (or a maximum of six documents) is listed. Next, consider the 'Queue Session Request' portion of the display. Normally, the session being scheduled should go to the tail of the queue (the default condition); however, if desired, touch RETURN to move the cursor from the DOCID list to the queue default condition and then use the space bar to select the 'head of queue' alternative. (The time of day specification is not supported by software Release 15.3T4/5.3T4) Finally, touch EXECUTE.

5. The main menu reappears and the scheduled session is logged into the session queue automatically. If additional documents are to be sent to the same remote facility, repeat step 1 through 4 as often as necessary to specify all the documents.
6. To check what was scheduled for a particular active or ready session, go to the telecommunications menu and select "Display Telecommunication Session Request". Enter in the session I.D. number and the system will display:

```
Session ID: 0003A
Connection 2780
Baud
Telephone
Docid
0001A
0002A
0003A
0005A
0007B
0009N
```



If the displayed session is a receive only session, then there will be no document I.D. number displayed under Docid.

7. When convenient, use the modem telephone to initiate a connection with the remote facility. (see section 3.5.5)

If null modem connection is used, the document entered will transmit immediately.

### 3.5.3 THE BACKGROUND ACTIVITY

Communications sessions remain in the session queue until a telephone connection between the Wang Word Processor and a particular remote site is established. Then, the communications controller begins with the session currently at the head of the queue. If the remote facility is ready to send documents to the local Wang Word Processor, reception may occur first. After the last document in the list is sent, the controller switches to the receive mode and waits approximately 23 seconds to allow reception to begin. Received documents are assigned the next available document I.D. number automatically by the system. If reception does not begin during the timeout interval (short timeout), the controller examines the session queue. If another session is ready in the queue, the controller automatically cancels the current session and handles the next session. On the other hand, if no other sessions are ready in the queue, the controller does not cancel the current session. Instead, as long as the telephone connection continues, the last session remains active and reception can occur at any time unless an operator manually cancels the session as described in Section 3.5.7 or if the long timeout is active as described in section 3.2.4.

### 3.5.4 CHECKING THE SESSION QUEUE

To check the session queue, proceed as follows:

1. From the main menu, select 'telecommunications' and touch EXECUTE:

## WANG WORD PROCESSING SYSTEM

Please select next activity:

- . Edit Old Document
- . Create New Document
- . Print Document
- . Special Print Function
- . Document Index
- . Document Filing
- \* Telecommunications
- . Other Functions

2. When the telecommunications menu appears--

Select Telecommunications Action

- . Schedule a Telecommunication Session
- . Cancel a Telecommunication Session
- . Display Telecommunication Session Request
- \* Display Telecommunication Session Summary
- . Display Telecommunication Connections

Select 'Display Telecommunication Session Summary' and touch EXECUTE.

3. Now a summary of the currently queued sessions appears. In the following sample summary, an active, ready and abort session are in the channel 1 queue.

## Session Summary

Channel/ Class	Session ID	Connection ID	Status
1	0016A	2780	Active
1	0018A	WPS	Ready
1	0017A	2780	Abort

The Channel/Class refers to the setting of the Channel I.D. switches, (refer to section 2.3.3) at the present time, only one channel (#1) per Word Processing system is supported.

The status of a session can be Active, Ready, or Abort. The active session is the current session that the communications controller is handling. The ready session(s) are the sessions which will be actived when the present active session is finished. The Abort status indicates that a session was prematurely aborted and cancelled by the system (refer to section 3.5.8). Even though the aborted sessions have been cancelled and will never become active again, their status remains in the session summary at the bottom of the queue until the system is reset or until they are manually cancelled by the operator (refer to section 3.5.7).

After viewing the summary, touch CANCEL to return to the main menu.

### 3.5.5 ESTABLISHING A CONNECTION

After scheduling one or more sessions for a particular facility, an operator is ready to use the modem telephone to initiate a connection with the remote site. A typical procedure follows:

1. Depress the Talk button on the modem telephone.

2. Lift the handset from its cradle; then, dial the number of the remote facility. If a busy signal is heard, replace the handset and try again later. Otherwise, there are two cases to consider--

If the modem at the remote facility has an automatic answering capability, the device usually responds promptly and a high-pitched sound replaces the ringing signal. In such a case, depress the Data button on the modem telephone; then, replace the handset in the cradle. Small signal lights on the modem should indicate action at the beginning of the session; however, the modem signal lights may not show changes for periods of 20 seconds or longer even when there is no difficulty with the connection.

If a person responds at the remote facility, leave the modem telephone in Talk mode. Ask the person whether the remote site is ready to receive or send documents to the Wang Word Processor. (If another Wang Word Processor is at the remote site, remind the remote operator that a session must be scheduled to receive or transmit documents.) When the remote site is ready, depress the Data button on the modem telephone and replace the handset in its cradle.

### 3.5.6 VERIFYING SUCCESSFUL COMMUNICATIONS

Since document transmission and reception are background activities, an operator may wish to determine whether transmission or reception has occurred. From the session queue, as described in Section 3.6.4, an operator can check the status of a scheduled session and assume that successful transmission has occurred if the session no longer appears in the session summary. On the other hand, to obtain an index of documents received during communications sessions operating with the 2780, 3780, or 3780c protocols proceed as follows:

1. From the main menu, select 'Document Index' and touch EXECUTE.
2. When the following display appears--

DOCUMENT INDEX

Please choose one from each column:

LOCATION:	WHICH ONES:	AUTHOR/OPERATOR NAME
* System Disk	. All	
. Archive Diskette	* By Author	TC.....
. Printers	. By Operator	
	. In Use	(Enter TC here.)
	. Recovered	

accept the column 1 default choice 'System Disk' and touch RETURN to move the cursor to the next column. Use the space bar to chose 'By Author' in column 2; then, touch RETURN to move the cursor to column 3. Enter the code TC as the desired author, and touch EXECUTE.

3. An index, such as the following sample appears--

DOCID	NAME	OPERATOR	AUTHOR
0178G	Telecommunications	TC0003A	TC
0185G	Telecommunications	TC0004A	TC
0188G	Telecommunications	TC0007A	TC

Column 1 shows the ID (received documents follow the ID sequence of created documents). Column 3 shows the session identifier code, with the prefix TC and the number of the session during which reception occurred. Document and author names are fixed, as shown.

Documents received during WPS sessions retain the document and author names used at remote sites; however, the operator identity is replaced by a 16-character code which begins with the prefix TC, followed by the session ID, followed by a period, followed by DOC, followed by the document ID used at the remote site--e.g., TC0006A.DOC0187G denotes reception of document 0187G during session 0006A. In step 2, choose 'All' to obtain an index with such codes.

### 3.5.7 CANCELING A SESSION

The last session in the session queue is not cancelled automatically by the system following a timeout after transmission of the last document, thereby allowing document reception to occur as long as the telephone connection continues, unless the long timeout is active (refer to section 3.2.4). However, to avoid excessive computer and telephone connection charges, an operator may wish to terminate the last session if no new session is to be scheduled for an extended period of time. If so, the currently active session should be cancelled by an operator before manually terminating the telephone connection; otherwise, the system interprets the disconnect as a line malfunction and aborts the session. Since a list of aborted sessions appears in the session summary, manual cancellation of any active session terminated by an operator's choice keep the session summary as brief as possible. Sessions that have a status of "Ready" or "Abort" can also be cancelled in the same fashion.

To cancel a session, proceed as follows:

1. From the main menu, select 'Telecommunications' and touch EXECUTE.

2. When the telecommunications menu appears--

Select Telecommunications Action

- . Schedule a Telecommunication Session
- \* Cancel a Telecommunication Session
- . Display Telecommunication Session Request
- . Display Telecommunication Session Summary
- . Display Telecommunication Connections

select 'Cancel a Telecommunication Session' and touch EXECUTE.

3. Then, a prompt appears below the menu--

Please enter Session ID: .....

Respond by entering the ID number and touching EXECUTE.  
After the connection name is displayed, touch EXECUTE again.

4. The specified session is now cancelled, and the main menu reappears automatically.

### 3.5.8 ABORTED SESSIONS

A session may be aborted for one of the following reasons:

- . an operator initiates a connection with a remote facility, but the connection fails after that data button on the modem telephone is depressed.
- . a telephone line malfunction occurs after a connection has been established.
- . an operator disconnects the modem telephone without manually canceling the session beforehand.

If document transmission or reception is in progress when a session is aborted, an incomplete operation occurs. Any document whose reception is interrupted is identified by a pound-sign (#) placed in the third position of the comment line in the document summary. (Refer to section 4.5.2 to determine why the session was aborted).

### 3.6 SOFTWARE CORRECTIONS AND IMPROVEMENTS

1. Problems with using Center Codes in documents transmitted/received in non-WPS connections are corrected. Previously unpredictable results could occur if Center Codes were used.
2. Documents received during a 3780 or 3780c connection will not have extra blank lines (Carriage Return Codes) generated.
3. The situation where the session is cancelled by the receiving station is now detected and causes the session at the transmitting station to be aborted. Previously if the transmitting station failed to react to this situation, the documents being transmitted would remain "IN USE" until either the session was manually cancelled by the operator or the system was reset.
4. The Line Drop condition (DSR goes off) is now detected and aborts the session even when no activity has occurred on the line.
5. An illegal received character will be stored in the document as two underlined hex digits representing the received value.
6. The Author field of documents received during a non-WPS connection will be "TC". This facilitates searching the document index.
7. Document to be transmitted in a session which is cancelled before it becomes active will not be left "IN USE".



8. Documents received during a non-WPS connection will have the system default print menu parameters.
9. Duplication of data in documents which are aborted while being received is eliminated.
10. Several code translations are changed for compatibility with the IBM ink-jet printer.
11. The default rate for the null modem is changed from 4800 baud to 2400 baud.
12. Corrected problem that if line transmission problems occur, the software will respond to the transmitting stations ENQ as if it were a line bid with a ACKO instead of treating it as a request to re-transmit the previous response. If the ACKO is the incorrect response, then the transmitting station will abort its session after 15 re-transmissions.
13. Corrected problem that documents containing format lines with either 1/4 (Q), 1/2 (H), or 1-1/2 (W) vertical spacing codes could be transmitted only in the WPS connection (system will transmit junk continuously in other connections).
14. Corrected problem when using either the WPS or 2780 // connection, if the text of a document to be transmitted contained an inserted format line, then when the document is received by another WWPS it is possible that a format character could be inserted into the document text.
15. Aborted sessions now appear in the Session Summary with Status = Abort and can be manually cancelled by the operator. Documents which have not been sent when the session was aborted will remain "In Use" until the session is cancelled.

16. A new connection, 2780v, is provided to send variable length printer records (with escape sequences) to a 2780 terminal.
17. A problem caused when the disk becomes full has been corrected. This problem could cause a work station to blow up after the TC encountered a disk full condition.
18. Disconnect logic has been added. If a session terminates and the next session queued is for a different connection (or there is no session queued), the TC issues a disconnect both for itself and to the remote end. There is a field in the Session Control Block which can be zapped to cause the session to terminate after a specified time of inactivity. Use of this feature prevents the telephone connection from being held longer than necessary.
19. It is now possible, during send, to distinguish between underlined and non-underlined characters by zapping the WWPS/EBCDIC Translation Table.
20. A problem caused by compressing more than 63 spaces in 3780 compress mode has been corrected.
21. A problem caused when a received document end in the last byte of a sector has been corrected. This problem caused the work station to blow up in the editing of the document.

### 3.7. SOFTWARE RESTRICTIONS

1. When data is transmitted in transparent mode from a host computer to a WWPS, invalid documents will be created unless the computer supplies all WPS required control information (e.g. Format, etc.). This means that, in general, punch output is not supported. An exception occurs when the computer simply returns a document that it has received transparently.
2. Incompatible disciplines (e.g. 2780 sending to WPS) causes invalid documents to be created.

3. In preparing a disk for TC on a system 20, do not use the "Create Systems Disk Using Old ID's and Format" function. Instead use the "Create Systems Disk - Initial ID's and Format" function. This also applies for Async.
4. Precautions must be taken to insure that the System Disk (primarily Editing Station/WP10A/WP20) is not completely filled-up while receiving a document that is too large for the remaining space. The receiving system will abort the session and unpredictable results may occur.
5. In the non-transparent transmission mode only software doesn't allow for transmission/reception of horizontal scroll documents that contain more than 80 characters per line. Received documents are automatically assigned a horizontal format of 80 characters per line. Documents with more than 80 characters per line are truncated at 80 characters with the truncated information not transmitted.

### 3.8 ERROR MESSAGES ISSUED DURING TC SYSTEM UPDATING

The following codes are used to indicate during which operation(s) a message might be issued:

- 1 -- COPY NETWORK AND SOFTWARE TO SYSTEMS DISK
  - 2 -- UPDATE NETWORK ON SYSTEMS DISK
  - 3 -- UPDATE NETWORK ON COMMUNICATIONS DISK
- 
- . ERROR: CANNOT READ/WRITE DISK IN ARCHIVE DRIVE  
(1, 2, 3)
  - . ERROR: CANNOT READ/WRITE DISK IN SYSTEM DRIVE  
(1, 2, 3)
  - . ERROR: CANNOT READ/WRITE SEALED DISK  
(1, 2, 3)
  - . ERROR: NO COPY -- CLEAR DOCUMENT AREA  
(1)

All the documents on the Systems disk must be archived (using standard procedures) before retrying the operation.

Note: If the Systems disk had TC software and a network prior to the operation, they are lost.

ERROR: NO COPY/UPDATE -- UPDATE SYSTEMS DISK TO REV. XXXX  
(1, 2, 3)

The label of both the Communications disk and the Systems disk, located at track 0 -sector 0, has a 4 character revision field at byte offset 5C. The above message is issued if the two revision fields are not compatible. To be compatible, the 1-st, 2-nd, and 4-th characters must be identical. (The revision displayed in the message is that of the Communications disk).

ERROR: NO UPDATE -- NEED MORE SPACE  
(2)

There isn't enough space on the Systems Disk for the network to be copied from the Communications Disk, so space should be made available by archiving documents. Because there are no restrictions on the placement of the network, one may archive 1 or 2 documents at a time (using standard procedures) and retry the operation until it succeeds.

Note: If the Systems Disk has a network prior to the operation, it is lost.

ERROR: SYSTEMS DISK MUST HAVE TC SOFTWARE  
(2, 3)

The selected operation can be performed only if the Systems disk already has TC software. The Systems disk label, at track 0 -- sector 0, has a TC flag at byte offset 1D. If the Systems disk has TC, then flag = FF; otherwise, flag = 00.

SORRY, TC SYSTEM UPDATING ALREADY IN PROGRESS  
(1, 2, 3)

Only one work station can perform a TC maintenance operation at any given time.

### 3.9 BSC DATA TRANSLATIONS

#### 3.9.1 INTRODUCTION

The Wang Word Processing System (WWPS) has a comprehensive telecommunication system which enables it to transmit and receive stored documents between its system disk and either another WWPS or a host computer/compatible terminal. This section describes how the code translation is done between the WWPS stored data code set (modified ASCII) and the EBCDIC code set which is used in emulating an IBM 2780 or an IBM 3780 Remote Job Entry (RJE) terminal.

### 3.9.2 DATA TRANSLATIONS

The final form of the data to be transmitted from the WWPS depends on the telecommunication connection which was scheduled. If data is to be transmitted between two WWPS's (connection = WPS), no code translation is performed on the stored WWPS document text. If the data is to be transmitted from a WWPS to host computer system or a compatible terminal using IBM Binary Synchronous Communications (BSC) terminal emulator protocol, then the final form of the data to be transmitted from the WWPS depends on whether the data is to be transmitted in transparent mode or non-transparent mode. In transparent mode (connection = 2780 or 3780 and // entered in the first two characters of the document comment field), all WWPS document control characters are translated into EBCDIC code set and transmitted. In non-transparent mode (connection = 2780, 2780v, 3780, or 3780c), the non-transparent code translation into EBCDIC code takes place.

#### WWPS-to-WWPS

STORED		TRANSMITTED/RECEIVED
<u>! WWPS !</u>	NO CODE TRANSLATION	<u>! WWPS !</u>
<u>! DOC. !</u>	-----	<u>! DOC. !</u>
<u>! CODE !</u>		<u>! CODE !</u>

#### WWPS-to-HOST (TRANSPARENT)

STORED		TRANSMITTED/RECEIVED
<u>! WWPS !</u>	CODE TRANSLATION	<u>! TRANSPT. !</u>
<u>! DOC. !</u>	-----	<u>! EBCDIC !</u>
<u>! CODE !</u>		<u>! CODE !</u>

#### WWPS-to-HOST (NON-TRANSPARENT)

STORED			TRANSMITTED/RECEIVED	
	CODE		CODE	
<u>! WWPS !</u>	TRANSLATION	<u>! WWPS !</u>	TRANSLATION	<u>! NON-TRANSPT. !</u>
<u>! DOC. !</u>	-----	<u>! INTERM !</u>	-----	<u>! EBCDIC !</u>
<u>! CODE !</u>		<u>! CODE !</u>		<u>! CODE !</u>

### 3.9.3 WWPS-to-WWPS DATA FORMAT

For this connection (connection = WPS), no code translation is performed on the stored WWPS document text. Data is transmitted in 256 byte sector image records containing document text codes exactly as they appear in the document. This makes available to the other WWPS all document text data containing:

The complete WWPS document character set

- Underscore information
- Subscripts and superscripts
- Formats and page-break formats
- Centered heading
- Indented paragraphs
- Decimal aligned numbers
- Merge and Don't Merge codes
- Stop codes
- Operator notes

#### 3.9.4 WWPS-to-HOST TRANSPARENT DATA FORMAT

For this connection (connection = 2780 or 3780 with // entered in the document comment field), the stored WWPS document text is translated into EBCDIC according to the WWPS STANDARD/INTERMEDIATE to EBCDIC-DP Code Translation Table (see table 3.5). Data is transmitted in 80 byte card image records containing document text codes exactly as they appear in the document, with the following exceptions: underscored characters are converted to non-underscored characters (unless they are redefined as described in section 3.2.5) and Don't Merge codes are effectively removed. This makes available to the host computer all document text data containing:

- The complete WWPS document character set
- Subscripts and superscripts
- Formats and page-break formats
- Indented paragraphs
- Decimal aligned numbers
- Merge codes
- Stop codes
- Operator notes

Data is received in reverse fashion with the received EBCDIC data being translated into WWPS STANDARD code according to the EBCDIC-DP to WWPS STANDARD/INTERMEDIATE Code Translation Table (see table 3.4).

#### 3.9.5 WWPS-to-HOST NON-TRANSPARENT DATA FORMAT

##### 3.9.5.1 GENERAL

For this connection (connection = 2780, 2780v, 3780, or 3780c), the stored WWPS document text is converted into non-transparent data format in a two-step process. First, the stored WWPS document text (see table 3.1) is translated into WWPS Intermediate code (see table 3.2) according to a WWPS Intermediate code translation table. The format of the data is also converted from a string of characters into a sequence of variable-length records whose format is independent of the transmission protocol. Finally, the data contained in these intermediate records is translated into EBCDIC according to the EBCDIC code translation table (see table 3.5) and is formatted into 80 character transmission records. In the case of 3780 emulation using space compression (connection = 3780c), the transmission records may contain less than 80 characters.

### 3.9.5.2 INTERMEDIATE DATA FORMAT

The intermediate records are print/display line images, and contain in addition to the text data a vertical function code which specifies the vertical paper advancement to occur following printing a record. The vertical function code is derived from a combination of the vertical format code (0, 1, 2, 3, Q, H, or W) obtained from the preceding document format and the removal of blank records which follow the record associated with vertical function code. It may contain the following values:

Vertical Function Code	Printer Function
X'00'	No Paper Advancement
X'01'	Space 1 line after print
X'02'	Space 2 lines after print
X'00'	Space 3 lines after print
----	-----
X'7F'	Space 127 lines after print
X'FC'	Space 1/4 line after print
X'FD'	Space 1/2 line after print
X'FE'	Space 1-1/2 lines after print
X'FF'	Form Feed

Both the stored document text and the intermediate record text are coded in a modified version of ASCII (see tables 3.1 and 3.2). In both cases an 8-bit character code consists of a 7-bit modified ASCII character and a additional bit (high-order bit) used to indicate underscoring of graphics. Data is translated between the intermediate and document codes with all codes being unchanged except for the following:

Character	WWPS Document Code	WWPS Intermediate Record Code
	CTR	X'01'
CR	X'03'	Deleted
IT	X'04'	Deleted
DAL	X'05'	Deleted
FMT	X'06'	Deleted
PG	X'86'	Deleted
DMG	X'8D'	X'00'
Underscore	X'A0'	X'06'

The translation of the above codes results in the high-order bit of the code only being used to represent underscoring of a non-blank graphic character.

### 3.9.5.3 DOCUMENT TO INTERMEDIATE TRANSLATION

The intermediate records are created for transmission from WWPS document text according to the following rules:

Formats are deleted. The most recent format is retained by translation logic to control the translation of the text data which follows the format, and to supply a value for the record's vertical format code.

Note codes defining the beginning of a operator note, the text that follows, and either the Carriage Return code or the Note code that ends the operator note, are deleted.

Document text is adjusted to appear as it would be if printed, with each print line image becoming a record. Center codes, Decimal Align codes, Horizontal Tab and Indent Tab codes are replaced by a string of spaces to make the record appear as it would if printed. Each record following an Indent Tab code, but preceding a Carriage Return code, begins with a string of spaces to indent the text as defined by the Indent Tab code. Carriage Return codes are deleted.

Document text codes are translated into intermediate record text codes (only underscore and Don't Merge characters are actually translated). Subscript, Superscript, Stop, Merge, and Don't Merge codes remain in the data with the other WWPS control codes having been removed.

### 3.9.5.4 TRANSMIT DATA TRANSLATION

#### EMULATING A 2780/3780

When the WWPS is emulating an IBM 2780 or 3780 terminal, the transmission card images (records) are created from intermediate records according to the following procedures:

First, WWPS intermediate record text is translated into EBCDIC according to the WWPS STANDARD/INTERMEDIATE to EBCDIC-DP Code Translation Table (see table 3.5). Underscored and non-underscored graphics are translated into the same code unless special transmit characters are defined (refer to section 3.2.5), underscore information therefore being lost. WWPS control codes remaining in the data are translated as follows:

WWPS Intermediate Record Code	Transmitted EBCDIC Code
DMG Don't Merge	(X'0C')
MG Merge	(X'2A')
SBS Subscript	(X'38')
SPS Superscript	(X'09')
STP Stop	(X'2F')



Next, records are truncated or padded with Space codes to exactly 80 characters in length. NOTE: For documents with more than 80 characters per line, the truncated characters are deleted and are never transmitted.

Finally, when the space compression parameter of 3780 emulation has been selected, strings of 2 to 63 spaces are replaced by a two character sequence consisting of the EBCDIC IGS code followed by a offset binary number formed by adding X'40' to the binary number of spaces (offsetting the number prevents its being aliased as a data link control character).

TRANSMITTING TO A 2780/3780

When the WWPS is transmitting to a 2780 or 3780 terminal the intermediate records are translated into transmission records as when emulating a 2780/3780 terminal with the following exceptions:

Records are not truncated or padded to 80 bytes, but remain variable in length.

A two character printer control sequence representing the vertical function code is appended to the beginning of the record. Since the 2780/3780 printers do not support quarter, half, one-and-a-half line spacing, records specifying them are given printer control sequences of single, single, and double line spacing respectively.

Record Prefix	2780/3780 Printer Function	Vertical Function Code
ESC M	No Paper Advancement (Sent to 3780 only)	X'00'
ESC /	Single Space After Print	X'01' X'FC' X'FD'
ESC S	Double Space After Print	X'02' X'FE'
ESC T	Triple Space After Print	X'03'
ESC A	Form Feed After Print	X'FF'

If the vertical function code for an intermediate record has the value of X'04' through X'7F', the printer control sequence for triple space is generated for the record. Then, to provide the printer advancement specified by the vertical function code, triple, double, and single space blank records are created. The result is that a blank line occurs on a 2780/3780 printer for each blank line in the WWPS source document.

### 3.9.5.5 RECEIVE DATA TRANSLATION

Received data translation is a sequence of blocked transmission records which are converted into intermediate records similar to the intermediate records used during transmission. The received EBCDIC data is translated to WWPS Intermediate code according to the EBCDIC-DP to WWPS STANDARD/INTERMEDIATE Code Translation Table (see table 3.4).

Received transmission records optionally contain a prefix which is used for device selection (printer or punch) and a printer advancement control. Additional printer control information may occur within a 3780 transmission record in the form of NL (new line), FF (form feed), and VT (vertical tab) codes. In these cases, the transmission record is divided into several intermediate records such that each record corresponds to one print/display line image.

Transmission	2780/3780
Record	Device
Prefix	Selected
ESC note	Printer
DC1	
ESC 4	
DC2	Punch
DC3	

Note: The character following the ESC for printer selection can be any printer control character such as / (print and single space) or a A (print and form feed).

Printer control transmission record prefixes and imbedded printer control characters are used to generate vertical function codes for intermediate records. If neither explicitly occurs, then a vertical function code denoting single space is generated.

Code Within Transmission Record	2780/3780 Printer Function	Vertical Function Code
NL*	Single space after print	X'01'
FF*	Form feed after print	X'FF'
VT ***	Channel 2 vertical tab	X'FF'

Record Prefix	2780/3780 Printer Function	Vertical Function Code
ESC M	No paper Advancement	X'00'
ESC /	Single space after print	X'01'
ESC S	Double space after print	X'02'
ESC T	Triple space after print	X'03'
ESC A	Form feed after print	X'FF'
ESC B**	Channel 2 vertical tab	X'FF'
ESC C**	Channel 3 vertical tab	X'FF'
ESC D**	Channel 4 vertical tab	X'FF'
ESC E**	Channel 5 vertical tab	X'FF'
ESC F**	Channel 6 vertical tab	X'FF'
ESC G**	Channel 7 vertical tab	X'FF'
ESC H**	Channel 8 vertical tab	X'FF'
ESC I**	Channel 9 vertical tab	X'FF'
ESC J**	Channel 10 vertical tab	X'FF'
ESC K**	Channel 11 vertical tab	X'FF'
ESC L**	Channel 12 vertical tab	X'FF'

- \* An imbedded printer control code divides a transmission record into two intermediate records with the generated vertical function code being associated with the first record.
- \*\* WWPS data does not have an equivalent structure for the 2780/3780 function "channel N vertical tab" except for the case of a channel 1 vertical tab which is a form feed. The other are not supported by the system and are treated as form feeds.

#### 3.9.5.6 INTERMEDIATE DATA TO DOCUMENT TRANSLATION

The intermediate records created from received transmission blocks are translated into document text according to the following rules:

At the beginning of a document, a page format line is generated having a vertical format code of 1 (single spacing), tabs in every fifth column, and a right margin in column 80.

Whenever the vertical function code changes among the values no-space, 1-127 spaces, quarter-space, half-space, and one-and-a-half-spaces, a new format line is created with the appropriate vertical format code. Any of the vertical function code values denoting spacing 1-127 lines cause the vertical format code to be set to single space. The other values (zero, quarter, half, and one-and-a-half space) cause the vertical format code to be set to the corresponding value. The format has tabs in every fifth column and a right margin in column 80.

When a vertical function code indicating form-feed occurs, a Page Break character is inserted and the page format line remains the same as the previous format line.

When a vertical function code indicating spacing 1-127 lines occurs, an appropriate number of Carriage Return codes is inserted into the document text.

Intermediate record text codes are translated into document text codes (only underscore and Don't Merge characters are actually translated).

A Carriage Return code is inserted into the document text following the translated intermediate record text.

TABLE 3-1  
WWPS DOCUMENT CODE SET  
Standard Version

		HIGH ORDER HEX DIGIT															
		0	1	2	3	4	5	6	7	8	9	A	B	C	D	E	F
L			^	SP	0	@	P	.	p		^	-	0	@	P	-	P
O			^	!	1	A	Q	a	q		^	!	1	A	Q	a	q
W	CTR		^	"	2	B	R	b	r		^	"	2	B	R	b	r
O			^	#	3	C	S	c	s		^	#	3	C	S	c	s
R	HT		^	\$	4	D	T	d	t		^	\$	4	D	T	d	t
D			^	%	5	E	U	e	u		^	%	5	E	U	e	u
E	DAL		^	&	6	F	V	f	v	PG	^	&	6	F	V	f	v
X	FMT		^	'	7	G	W	g	w		^	'	7	G	W	g	w
D			^	(	8	H	X	h	x		^	(	8	H	X	h	x
I	/		^	)	9	I	Y	i	y		^	)	9	I	Y	i	y
G	\		^	*	:	J	Z	j	z		^	*	:	J	Z	j	z
I	^		^	+	;	K	[	k	⌘		^	+	;	K	[	k	⌘
T	STP		^	,	<	L	\	l	⌘		^	,	<	L	\	l	⌘
A	NOT		^	,	<	L	\	l	⌘		^	,	<	L	\	l	⌘
B	MG		^	-	=	M	]	m	é	DMG	^	-	=	M	]	m	é
C	SPS		^	.	>	N	B	n	⌘		^	.	>	N	B	n	⌘
D	SBS		^	/	?	O	⌘	o	⌘		^	/	?	O	⌘	o	⌘

WANG WP CONTROL CHARACTERS

CR	Carriage Return
CTR	Center
DAL	Decimal Align
DMG	Don't Merge
FMT	Format
HT	Horizontal Tab
IT	Indent Tab
MG	Merge
NOT	Note
PG	Page
SBS	Subscript
SPS	Superscript
SP	Space
STP	Stop

TABLE 3-2  
WWPS INTERMEDIATE CODE SET\*  
Standard Version

		HIGH ORDER HEX DIGIT							
		0	1	2	3	4	5	6	7
L O W	0	DMG	^a	SP	0	@	P		p
	1		^e	!	1	A	Q	a	q
O R D E R	2	HT	^i	"	2	B	R	b	r
	3		^o	#	3	C	S	c	s
H E X D I G I T	4		^u	\$	4	D	T	d	t
	5		•a•	%	5	E	U	e	u
D I G I T	6	-	•e•	&	6	F	V	f	v
	7	••	•i•	'	7	G	W	g	w
I T	8	/	•o•	(	8	H	X	h	x
	9	\	•u•	)	9	I	Y	i	y
A	^	a	*	:	J	Z	j	z	
B	STP	è	+	;	K	[	k	§	
C	NOT	ù	,	<	L	\	l	↖	
D	MG	•A•	-	=	M	]	m	e	
E	SPS	•O•	.	>	N	B	n	ç	
F	SBS	•U•	/	?	O	π	o	ç	

\* Only the codes represented by the low-order 7 bits of the code are shown. In addition, the high-order bit denotes underscoring of graphics.

TABLE 3-3  
IBM EBCDIC-DP CODE SET

		HIGH ORDER HEX DIGIT															
		0	1	2	3	4	5	6	7	8	9	A	B	C	D	E	F
LOW ORDER	0	NUL	DLE			SP	&	-						{	}	\	0
	1	SOH	DC1			RSP		/		a	j	~		A	J		1
	2	STX	DC2		SYN					b	k	s		B	K	S	2
	3	ETX	DC3							c	l	t		C	L	T	3
	4									d	m	u		D	M	U	4
	5	HT	NL	LF						e	n	v		E	N	V	5
	6			ETB						f	o	w		F	O	W	6
	7			ESC	EOT					g	p	x		G	P	X	7
	8									h	q	y		H	Q	Y	8
	9		EM							i	r	z		I	R	Z	9
A					c	!		:									
B	VT				.	\$	,	#									
C	FF				<	*	%	@									
D	CR	IGS	ENQ	NAK	(	)	-	'									
E		IRS			+	;	>	=									
F		ITB	BEL			⌋	?	"									PAD

BSC DATA LINK CHARACTERS

BEL Bell  
 CR Carriage Return  
 DLE Data Link Escape  
 ENQ Enquiry  
 EOT End of Transmission  
 ESC Escape  
 ETB End of Text Block  
 ETX End of Text  
 HT Horizontal Tab  
 ITB Intermediate Text Block  
 NAK Negative Acknowledgement  
 NUL Null  
 PAD Trailing Pad Character  
 SOH Start of Header  
 STX Start of Text  
 SYN Synchronous Idle

## IBM 2780 CONTROL CHARACTERS

EM	End of Media
SP	Space

## IBM 3780 CONTROL CHARACTERS

DC1	Device Select Printer
DC2	Device Select Punch
DC3	Device Select Punch
FF	Form Feed
IGS	Interchange Group Separator
IRS	Interchange Record Separator
LF	Line Feed
NL	New Line
SP	Space
VT	Vertical Tab

## BSC DATA LINK CONTROL SEQUENCES

ACK 0	Positive Acknowledgment 0 (DLE X'70')
ACK 1	Positive Acknowledgment 1 (DLE /)
DLE EOT	Disconnect Sequence for a Switched Line
RVI	Reverse Interrupt (DLE @)
TTD	Temporary Text Delay (STX ENQ)
WACK	Wait-Before-Transmit Positive Acknowledgment (DLE ,)



TABLE 3-4  
 EBCDIC-DP TO WWPS STANDARD/INTERMEDIATE CODE  
 Code Translation Table

		EBCDIC HIGH ORDER HEX DIGIT																
		0	1	2	3	4	5	6	7	8	9	A	B	C	D	E	F	
E	B	0	80	C0	01	20	20	26	2D	C0	C0	C0	C0	C0	7B	7D	5C	30
C	D	1	C0	C1	0B	06	8D	C0	2F	C0	61	6A	7E	C0	41	4A	20	31
I	C	2	C0	C2	0C	C0	C0	C0	C0	C0	62	6B	73	C0	42	4B	53	32
L	O	3	C0	C3	C0	C0	C0	C0	C0	C0	63	6C	74	C0	43	4C	54	33
W	O	4	C0	C0	05	C0	C0	C0	C0	C0	64	6D	75	C0	44	4D	55	34
R	D	5	CE	CD	C0	C0	C0	C0	C0	C0	65	6E	76	C0	45	4E	56	35
E	R	6	C0	C0	C0	C0	C0	C0	C0	C0	66	6F	77	C0	46	4F	57	36
H	E	7	C0	C0	C6	C0	C0	C0	C0	C0	67	70	78	C0	47	50	58	37
X	E	8	C0	C0	C0	0F	C0	C0	C0	C0	68	71	79	C0	48	51	59	38
D	A	9	0E	20	C0	04	C0	C0	C0	09	69	72	7A	C0	49	52	5A	39
I	G	A	C0	C0	0D	86	7F	21	7C	3A	C0	C0	C0	C0	C0	C0	C0	C0
I	B	B	C7	C0	C0	C0	2E	24	2C	23	C0	C0	C0	C0	C0	C0	C0	C0
T	C	C	C7	C0	C0	C0	3C	2A	25	40	C0	C0	C0	C0	C0	C0	C0	C0
D	D	D	CD	CF	C0	C0	28	29	A0	27	C0	C0	C0	C0	C0	C0	C0	C0
E	E	E	C0	CD	C0	C0	2B	3B	3E	3D	C0	C0	C0	C0	C0	C0	C0	C0
F	F	F	C0	C0	0B	C0	5B	5D	3F	22	C0	C0	C0	C0	C0	C0	C0	C0

TABLE 3.5  
 WWPS STANDARD/INTERMEDIATE CODE TO EBCDIC-DP  
 Code Translation Table

		WWPS HIGH ORDER HEX DIGIT															
		0	1	2	3	4	5	6	7	8	9	A	B	C	D	E	F
W	0	0C	81	40	F0	7C	D7	3F	97	3F	81	6D	F0	7C	D7	3F	97
P	1	20	85	5A	F1	C1	D8	81	98	3F	85	5A	F1	C1	D8	81	98
L	2	05	89	7F	F2	C2	D9	82	99	3F	89	7F	F2	C2	D9	82	99
O	3	0D	96	7B	F3	C3	E2	83	A2	3F	96	7B	F3	C3	E2	83	A2
R	4	39	A4	5B	F4	C4	E3	84	A3	3F	A4	5B	F4	C4	E3	84	A3
D	5	24	81	6C	F5	C5	E4	85	A4	3F	81	6C	F5	C5	E4	85	A4
E	6	31	85	50	F6	C6	E5	86	A5	3A	85	50	F6	C6	E5	86	A5
H	7	3F	89	7D	F7	C7	E6	87	A6	3F	89	7D	F7	C7	E6	87	A6
X	8	3F	96	4D	F8	C8	E7	88	A7	3F	96	4D	F8	C8	E7	88	A7
D	9	79	A4	5D	F9	C9	E8	89	A8	79	A4	5D	F9	C9	E8	89	A8
I	A	3F	81	5C	7A	D1	E9	91	A9	3F	81	5C	7A	D1	E9	91	A9
T	B	2F	85	4E	5E	D2	4F	92	C0	3F	85	4E	5E	D2	4F	92	C0
C		22	A4	6B	4C	D3	E0	93	6A	3F	A4	6B	4C	D3	E0	93	6A
D		2A	C1	60	7E	D4	5F	94	D0	03	C1	60	7E	D4	5F	94	D0
E		09	D6	4B	6E	D5	3F	95	A1	3F	D6	4B	6E	D5	3F	95	A1
F		38	E4	61	6F	D6	3F	96	4A	3F	E4	61	6F	D6	3F	96	4A

RELEASE 15.3T4/5.3T4COM Disk Map

<u>Module</u>	<u>Disk Address</u>
Black Box IPL	2F,01
WWPS to ASCII	2F,02
ASCII to WWPS	2F,03
TC Initial Load	30,00 - 30,09
TC Common	30,00 - 30,04
PL/M IPL	30,05 - 30,08
Move Rtn	30,09
Initiate Session	30,0A - 30,0F
Send IO Utility	31,00 - 31,03
Recv IO Utility	31,04 - 31,0D
WWPS to EBCDIC	31,0E
EBCDIC to WWPS	31,0F
Send File Utility	32,00 - 32,06
Recv File Utility	32,07 - 32,0A
Batch Driver Main	32,0B - 32,0F
Bisync Send Data U	33,00 - 33,05
Batch Driver-Send	33,06 - 33,0A
Batch Driver-Rcev	33,0B - 33,0F
Bisync Xmission U	34,00 - 34,0A
Menu 23 Overflow	34,0B
CSB - 1	34,0C
Establish Connection	34,0D - 34,0E
BCB - Async	34,0F
Bisync Recv Data U	35,00 - 35,05
Buffer Routines	35,06
MSL	35,07
Print Queue	35,08
QCB	35,09
Admin Block	35,0A
MDB	35,0B
QCB Initial	35,0C
SCB Initial	35,0D
MCB	35,0E
BCB - Batch Bisync	35,0F
PSB	36,00
Menus - 09	36,01 - 36,03
- 18	36,04 - 36,05
- 19	36,06 - 36,08
- 20	36,09 - 36,0A
- 21	36,0B - 36,0C
- 22	36,0D - 36,0E
- 23	36,0F (+34,0B)

Pak 4 -	37,00 - 39,09
Menus 6	37,00 - 37,0F
Menus 7	38,00 - 38,0C
Menus 8	38,0D - 39,09
Pak 5 - Menus 9	39,0A - 3A,09
Work Station IPL	3A,0A
Interactive Driver	3A,0B - 3A,0F
Async Xmission U	3B,00 - 3C,03
Spare	3C,04 - 3C,05
MCB - OCR	3C,06
BCB - OCR	3C,07
Admin Block - OCR	3C,08
SCB Initial - OCR	3C,09
OCR to WWPS	3C,0A - 3C,0F
OCR Xmission Utility	3D,00 - 3D,04
OCR Driver	3D,05 - 3D,06
WWPS to Corr	3D,07
Corr to WWPS (l)	3D,08
WWPS to Corr (u)	3D,09
2741 State Tables	3D,0A - 3E,02
TTY State Tables	3E,03 - 3E,0B
TTY XU (temp.)	3E,0C - 3F,0F

NOTE:

Disk Maps for the System Disk are not being distributed with this release because the maps vary according to the software selected. The MCB, whose format is shown in one in the 'TC Modules and Control Blocks' (Refer to Section 3.10.3), contains the disk addresses of all the remaining modules and control blocks. The address of the MCB itself is given in bytes OD-OE of 00,0E (the communications controller's IPL sector), and in this release is 20,00 for the 20 and 2D,00 for the 30 (assuming no PIO).

3.10.2 TC CONTROLLER MEMORY LAYOUT

Release 5.3T4/15.3T4

Low 8K - All Processors*			Hi 8K - 928 Processor				
0000	!	Interrupt Rtn's **	!	2000	!	SCB	!
0100	!	non-928 IO ***	!	2100	!		!
0200	!		!	2200	!	TC Common	!
0300	!		!	2300	!		!
0400	!	Task Control	!	2400	!		!
0500	!		!	2500	!		!
0600	!		!	2600	!		!
0700	!	XU/DU Buffers	!	2700	!	Driver	!
0800	!		!	2800	!		!
0900	!		!	2900	!		!
0A00	!		!	2A00	!		!
0B00	!		!	2B00	!		!
0C00	!	XU	!	2C00	!	IO Send I/O Recv	!
0D00	!		!	2D00	!		!
0E00	!		!	2E00	!		!
0F00	!		!	2F00	!		!
1000	!		!	3000	!	FU Send	!
1100	!		!	3100	!		!
1200	!		!	3200	!		!
1300	!		!	3300	!		!
1400	!		!	3400	!		!
1500	!		!	3500	!	FU Recv	!
1600	!	DU Send/DU Recv	!	3600	!		!
1700	!		!	3700	!		!
1800	!		!	3800	!		!
1900	!		!	3900	!	FMT	!
1A00	!		!	3A00	!	IO QCB	!
1B00	!		!	3B00	!	Buffers	!
1C00	!	BUR/STK **	!	3C00	!	MCB	!
1D00	!	CT Send/CT RECV	!	3D00	!	PGE	!
1E00	!	not used	!	3E00	!	ASM !	!
1F00	!	BCB	!	3F00	!	PL/M Variables	!

\* : On the 2200, this 8K of memory starts at address 1000.

\*\* : On the 2200, these two sectors are interchanged.

\*\*\*: On the 928, this sector is used by debug.

3.10.3 TC MODULES AND CONTROL BLOCKS

MODULES

Modules are classified by type. The type determines the memory in which the module executes, the conditions under which the module is invoked, and the availability of other modules and data to the modules of that type.

## 1. TC (Telecommunications Common) Type

These modules are common to all disciplines and operating modes.

- a) TC Loading - The Black Box IPL sector for Bisync and OCR, the TC Work Station IPL sector for the TC Work Station.
- b) TC Common - The TC Sequencer, which sequences through the phases of a session and loads the other modules in turn. Also includes subroutines to communicate with the Master for disk IO, disk space, inter-slave communication, etc.
- c) TC ASM - Assembly Language subroutines, currently only the Move Characters subroutine.

## 2. QD (Queue Driver) Type

These modules execute when no session is in progress, and perform pre-session or post-session processing involving operation on the QCB.

- a) PL/M IPL - This module is called in by the IPL sector to complete the IPL processing and the start a session if one is queued or this is an OCR box.
- b) Initiate - This module is called in after PL/M IPL and between sessions. After deleting any completed session from the queue, it initiates the next session or waits for a Start from the Master. Not used for OCR.

## 3. BD (Buffer Driver) Type

These modules execute during a session and drive the remaining session modules using the Buffer Control Block as the control mechanism.

- a) BD Establish - Invokes the Transmission Utility (XU) to initialize as necessary and wait for the Data Set Ready signal.
- b) Batch Driver Main - Invokes Send and Receive as appropriate during a batch session.
- c) Batch Driver-Send - Controls the Send portion of a batch session.
- d) Batch Driver-Recv - Controls the receive portion of a batch session.
- e) Interactive Driver - Controls sending and receiving of documents during an interactive session.
- f) OCR Driver - Controls receiving of documents for OCR.

## 4. IO (Input/Output) Type

These modules operate during a session.

- a) IO Send - Accesses documents during the send portion of a batch session. Not used for OCR.
- b) IO Receive - Stores documents during the receive portion of a batch session and for OCR.

## 5. FU (File Utility) Type

These modules operate during a session.

- a) FU Send - Performs file formatting operations (tabbing, centering, aligning, adjusting, etc.) on documents being sent. Not used for OCR.
- b) FU Recv - Performs file formatting operations (format line generation, sector formation, etc.) on documents being received. Not used for OCR.

## 6. DU (Data Utility) Type

These modules operate during a session (Bisync only).

- a) DU Send - Performs data and code translation on data being sent.
- b) DU Recv - Performs data and code translation on data being received.

## 7. XU (Transmission Utility) Type

These modules operate during a session.

Bisync XU - Sends and receives Bisync data.

Async XU - Interfaces with the user at the screen, sends and receives Async data.

OCR XU - Receives OCR data and formats it as a WPS document

## 8. CT (Code Translation Table) Type

- a) WWPS/EBCDIC
- b) EBCDIC/WWPS
- c) WWPS/ASCII
- d) ASCII/WWPS
- e) WWPS/Correspondence
- f) Correspondence/WWPS
- g) WWPS/OCR
- h) OCR/WWPS

## 9. BUR (Buffer Routine) Type

- a) Buffer Routines - subroutines to assign buffers to tasks.

## 10. Menu Type

These modules operate in the work station slave and process the TC menus.

## CONTROL BLOCKS

1. Module Control Block (MCB) - one for the TC system and one for OCR. Contains the disk addresses of all other modules.
2. Session Control Block (SCB) - one for each session. Contains information about the session, including the session ID and the list of documents to be sent.

The SCBI contains initial values for the SCB, copied at session scheduling time. The OCR has its own SCBI containing the fixed values for an OCR "session".

3. Queue Control Block (QCB) - one for the system. For each port (currently only one), it gives the disk address of the currently active SCB. For each class of ports (also currently only one) it gives the count and head and tail pointers of the sessions queued for that class. Not used for OCR.

The QCBI contains the initial values for the QCB, copied at System IPL time by the WP Master. Not used for OCR.

4. Buffer Control Block (BCB) - one for Batch Bisync, one for Interactive Async, and one for OCR. Contains task and buffer control information and line status information.
5. Connection Specification Block (CSB) - one for each connection (currently 2780 and WPS). Specifies the discipline for that connection. Later will contain other information such as telephone number, etc. Not used for OCR.
6. Port Specification Block (PSB) - one for the system. Not used during system operation except as a link to the CSB's. Not used for OCR.
7. Print Queue Initial Block (PQI) - one for the system. Used to initialize the print request when documents are queued for printing.
8. ADMIN Initial Block (ADI) - one for the TC system and one for OCR. Used to initialize the ADMIN Block for non-WPS received documents.
9. Menu Display Block (MDB) - one for the system. Contains the English names for Baud rates and disciplines, for display on the menus. Not used for OCR.





.E0.	.C0.	.A0.	.80-- 3rd cnn
			0
			1
			2
			3
			4
			5
			6
			7
			8
			9
			A
			B
			C
			D
			E
			F
			0
			1
			2
			3
			4
			5
			6
			7
//////			8
//////			9
			A
			B
		4th cnn	C
			D
			E
			F

.60.	.40.	.20.	.00--
		DISC	D! BLOK
		ID	I! NEXT
			S! NEXT
		CT ID	C! K! 1
			I! K! 1
			P! K! 1
		DISC	L! BLOK
		FLAGS	I! END
			E! 2
			A! 2
		BAUD	E! BLOK
			I! TYPE
			E! 3
			R! 3
	2nd cnn	PARITY	P! BLOK
			E! ID
			I! 4
		not used	I!
			F! 5
			I! 5
		TERMIN	C! A!
			I! 6
			A! 6
			I! BLOK
			O! CODE
			I! 7
			N! 7
			CNN
			ID
			N! 8
			N! 8
			G! 9
			R! 9
		SELECT	P! A
			I! A
			I! B
			/! B
			.40!
			b! C
			v! C
			t! C
			e! D
			s! D
			p! E
			e! E
			r! F
			I! F
		EXT	PORT
			TYPE
			c! 0
			n! 0
			n! 0
			SESS
			CODE
			e! 1
			c! 1
			ESTAB
			t! 2
			i! 2
			o! 2
			DISC
			n! 3
			/! 3
			not
			used
			I! 4
			I! 4
			I! 5
			I! 5
			I! 6
			I! 6
			I! 7
			I! 7
			FEL
			NO
			I! 8
			I! 8
			I! 9
			I! 9
			A
			A
			B
			B
			C
			C
			D
			D
			E
			E
			F
			F

C  
O  
N  
N  
E  
C  
T  
I  
O  
N  
  
S  
P  
E  
C  
I  
F  
I  
C  
A  
T  
I  
O  
N  
  
B  
L  
O  
C  
K

.EO.	CO	AO	RO
//////////	4th class	3rd class	0
//////////			1
			2
			3
			4
			5
			6
			7
			8
			9
			A
			B
			C
			D
			E
			F
			0
			1
			2
			3
			4
			5
			6
			7
			8
			9
			A
			B
			C
			D
			E
			F

60	40	20	00
2nd class	PORT C!	3rd port	BLOK B!
	TYPE L!		NEXT L! 0!
	LINE S!		CI O!
	SW S!		K! 1!
	CNN C!		BLOK H!
	ID R!		END E! 2!
	.P!		A!
	(for		BLOK D!
	leased		TYPE E! 3!
	lines)		R!
	/!		4!
	32!		5!
	b!		6!
	y!		7!
	e!		BLOK
	s!		CODE
	p!		PORT
	e!		ID
	c!		O! 8!
	l!		R!
	a!		CCE
	s!		T! 9!
	s!		G!
	TOP		ACTV
	IDLE		R!
	/!		LS
	not		P! A!
	used		B!
	H	4th	H
	CLASS Q	port	PORT Q
			12!
			C!
			b!
			y!
			t! D!
			e!
	T		T
	CLASS Q		PORT Q
			s!
			E!
			p!
			e!
			r! F!
	H		PORT Q
	TIME Q		p!
			CNT
			o! 0!
			r!
			NEXT
			IDLE
			t!
			1!
	T		PORT
	TIME Q		STAT
			2!
			DEVID
			3!
	H		2nd port
	ABORT		4!
			5!
			6!
	T		ABORT
	ABORT		7!
			8!
	QSEM	not used	9!
	CNT		A!
	TIME Q		B!
	CNT		C!
	ABORT		D!
	CNT		E!
	WUP		F!
	YY		
	WUP		
	MO		
	WUP		
	DD		
	WUP		
	HH		
	WUP		
	MI		

Q  
U  
E  
R  
Y  
  
C  
O  
N  
T  
R  
O  
L  
  
B  
L  
O  
C  
K

ED	CO	A0	80
not used	RDOC STAT	SHORT TIMEOUT	DISC ID
SDOC NAME	RDOC NAME		CT ID
		LONG TIMEOUT	DISC FLAGS
			BAUD
	not used		PARITY
			not used
			TERMIN
			SELECT
		CS EXT	
			LINE STAT
			IO STAT
			TBLOK CTR
			RBLOK CTR
			SYS MODE
			TNAK CTR
not used	RDOCID		RENQ CTR
			RNAK CTR
SEND PAGE	RCV PAGE		
SEND LINE	RCV LINE		RTMOT CTR

60	40	20	00
		SESS ID	BLOK NEXT
	4th doc		BLOK END
		not used	BLOK TYPE
			BLOK ID
			START
		START YY	BLOK CODE
	5th doc	START MO	CNN ID
		START DD	
		START HH	
		START MI	
		DCNN	
		USE PORT	
	6th doc	VOL RECV	
		DISPO	
		DOCID	S PORT
			E TYPE
			D SESS CODE
			O ESTAB
		DOC SENT	G DISC
	not used	DOC LS	not used
			/
		2nd doc	b y t e s
END DOC			p TEL
SESS STAT			e NO
PAGE			d
CC			c u m e n t
RETRY CNT		3rd doc	/
//////////			
//////////			

S  
E  
S  
S  
I  
O  
N  
C  
O  
N  
T  
R  
O  
L  
B  
L  
O  
C  
K

EO	CO	AO	.80
		EBCDIC to WWPS	C! Bisync T! DU Send U! 0
			L! S!
			L! S! 1
			-! -!
			2!
			R! S!
			E! N! 3
			V! D!
			4!
			5!
			6!
			7!
			D! Bisync I! DU Recv U! 8
			S! C!
			L! S! 9
Async BCB			D! -!
			A
			E!
			N! B
MDB			D! I!
			C
			S!
			C!
			D
SCB Initial			T! E
			F
			F
BCB	Work Sta. IPL	Bisync XU	X! U! 0
			L! S! 1
QCB	OMCB		2
			3
QCB Initial	MSL CODE		4
			5
Print Queue		Async XU	6
			7
ADMIN BLOCK		WWPS to EBCDIC	C! T! 8
			L! S! 9
PSB			-! A
			S! E!
			N! B
PAK 4 LS			D! C
			D
PAK 5 LS		ASCII Trans. (Send/ Recv)	E! E! F

.60	.40	.20	.00
F! U!	I! O!	D! R!	BLOK NEXT L! 0
L! S!	L! S!	V! E!	C! K! 1
		R!	
		-!	BLOK H! 1
		L!	END E! 2
		S!	
		E!	BLOK D! 1
		N!	TYPE E! 3
		D!	R!
		S!	BLOK
		E!	ID
		N!	
		D!	
			5!
			6!
			BLOK CODE
Send File Utility	Send IO Utility	Batch Dr. -Send	TC SIZE 8
			Base TC Size
			9
			TC Initial Load Module
			A
			B
			Buffer Routines
			C
			D
			Black Box IPL
			E
			F
			F
F! U!	I! O!	D! R!	Initiate Session R! 0
L! S!	L! S!	V! E!	V! E! 1
		R!	
		-!	Estab. L! Cnn L! 2
		R!	S!
		E!	
		C!	-! 3
		V!	
		R!	M!
		E!	A! 4
		C!	I!
		V!	N!
			5
			Int'active Driver
			6
			7
Recv File Utility	Recv IO Utility	Batch Dr. -Recv	Batch Dr. -Main
			8
			9
			A
			B
			C
			D
			E
			F

M  
O  
D  
U  
L  
E  
  
C  
O  
N  
T  
R  
O  
L  
  
B  
L  
O  
C  
K

**4**

**DIAG-  
NOSTICS**

## 4. DIAGNOSTICS

### 4.1 TC DIAGNOSTICS

#### 4.1.1 INTRODUCTION:

The On-Line Telecommunications Diagnostic is designed to run on a Wang 928 Word Processing System with a 928 Telecommunications Slave attached to the system. It can be operated either from a debug monitor<sup>1</sup> or a WPS Workstation. It is intended to be used as a tool in testing the TC black box and defining the area in which the TC slave is failing. This diagnostic is part of the 928 on-line diagnostic command processor. Before using this diagnostic, you should be familiar with the operation of the WPS diagnostic command processor. As an additional hardware check, either the F13.0 (single PROM system) or E13.0 (dual PROM system) system checkout disk should be run to check most of the hardware.

#### 4.1.2 EQUIPMENT REQUIREMENTS

- 1) System Checkout Disk E13.0
- 2) Any 928 WPS System Configuration
- 3) Telecommunications Black Box <sup>2</sup>
- 4) RS-232 Loop-Back Clip
- 5) TC Debug Monitor <sup>1</sup> (Optional)

#### 4.1.3 TC TEST OPERATION USING THE DIAGNOSTIC COMMAND PROCESSOR

To operate the On Line Diagnostic on the Word Processing system, go to "Edit Old Glossary". Key in document I.D. "0000D", mount the System Checkout diskette in the archive drive, and hit EXECUTE. the Diagnostic Command Processor software will then be disk loaded into the workstation slave. This slave now serves as the operator's console for the system. The state of the system and various peripherals may be checked and tested by the use of the Diagnostic Command Processor.

- 1 Requires specially modified debug monitor with a 7257 PCB in place of the 7251 PCB.
  - 2 ECN #8468 (refer to section 5) must have been performed for the On-Line TC Diagnostics to operate properly.
- The first prompt to appear on the screen is as follows:

ENTER PASSWORD:

The correct password must be entered. You have only three tries at the password before the system will refuse to activate the Command Processor. If you are not successful in three tries, the slave will be re-loaded with the startup menus. The current password for the E13.0 System Checkout Disk is:

\$WPS/13/0/12/9/D

CAUTION:

Misuse of the Command Processor can cause system integrity to be lost. Exercise extreme caution when directing tests to specific slaves. The Command Processor commands concerning testing slave channels, override all system activity! i.e., IF A MEMORY DIAGNOSTIC IS TO BE DONE ON CHANNEL 13 AND IT IS SENT TO CHANNEL 14 BY MISTAKE, ALL/ANY ACTIVITY ON CHANNEL 14 IS HALTED. MEMORY TESTING IS INITIATED, AND ALL PREVIOUS ACTIVITY IS LOST.

The next piece of information prompted for is the system configuration (i.e., number of slave channels). The "Command Processor" channel is also shown at this time.

Note: Some slave testing cannot be done on the command Processor channel.



The workstation now enters the "Command:" mode and is ready to accept commands. After any command is executed, the workstation always returns back to command mode.

To invoke the On-Line Telecommunications Diagnostic from the WPS Command Processor, enter the command TC in the normal manner. This causes you to enter the TC command. First, the user will be prompted to select the channel that the TC slave is on as follows:

Slave channel to be selected (HEX):

Next the operator is prompted to select a command from the list displayed:

CHOOSE: 1) loop-back.  
2) loop-back, sync.  
3) loop-back, sync, clock.  
4) loop-back, sync, clock, xmit/rcv.  
5) loop-back, sync, clock, xmit/rcv, interrupts

Key in the number of the desired command. The next question to be prompted for is the test rate:

CHOOSE: 1) single test 2) continuous test.

Select the desired rate by hitting the appropriate key. If continuous is chosen, a prompt to select the error collection mode will be given, as follows:

CHOOSE: 1) stop on error 2) save errors.

Stopping on an error will run the test until it comes to an error, while saving them will execute the test until you wish to stop the test. This is accomplished by hitting cancel. The selection of the clock rate is chosen after selecting single test in the test rate choice or after the error collection mode if continuous was chosen.

CHOOSE clock rate: 1) 2400 2) 4800 3) 9600 baud.

After the test parameters have all been entered, the test is executed by the TC slave. When the slave is in execution (in this example, continuous test rate has been selected) the following messages will be seen near the bottom of the screen:

```
Interrupts test.  
Hit CANCEL to halt the test run.  
TC Test Passes: 20a3
```

Upon completion of a successful test run, the following will appear:

```
NO errors were encountered in the test run.
```

Otherwise, a failure is indicated by this message:

```
ERRORS were encountered in the test run.
```

A continuous test will continue to execute until cancel is hit. The success of the run and number of tests performed will be presented on the screen. At this point, a prompt will be presented for you to indicate if you'd like to see the errors. This can be accomplished by hitting execute.

After viewing the errors, hitting cancel will result in the prompt:

```
EXECUTE to run test again.
```

Hitting execute at this time will result in the test being run again using the current test parameters as defaults. The number of test passes is updated to keep track of how many times the test has been run.

#### 4.1.4 OPERATION USING THE DEBUG MONITOR

Configure the Word Processing System normally with the TC Slave attached, and use normal system software. Invoke the Command Processor. The LOAD PROGRAM command may be used to load the TC test into the black box, using 0200 for the memory starting address, 0025 for the disk address and 10 for the sector count.

If the TC program is loaded in properly, a menu should appear on the debug monitor with a prompt asking for a command. Select a command from the list on the screen, and depress the corresponding key on the keyboard. The title of that test will appear at the top of the screen, and a prompt for selection of the test rate near the bottom.

##### KEY CODES FOR COMMANDS:

- l) LOOP BACK TEST
- s) TRANSMITTER/RECEIVER SYNC TEST
- c) CLOCK TEST
- x) TRANSMIT/RECEIVE TEST
- i) INTERRUPT TEST

##### SELECT COMMAND FROM LIST

Choose either a single test run (s) or a continuous test run (c). This selection will appear under the test title and a prompt for the error mode will come up. The error modes are stop on an error (s) or collect all errors (c). If a single test is chosen, the "TEST COMPLETED" prompt will appear immediately. If continuous, it will prompt:

## PROCESSING COMMAND, TO HALT THE S KEY

Hitting the s-key or cancel (upper case C) will stop the current test run.

The following prompt will appear:

TEST COMPLETED, HIT EXECUTE FOR ERROR CODES

Hitting cancel (upper case C) will cause the program to return to the start up menu. Hitting execute (return) will cause the error list to be displayed. If the error list is too large for the screen, you will be prompted for the rest of the list. Hitting execute will bring the next portion of the list to the screen, while cancel will return you the start up menu.

### 4.1.5 TECHNICAL DESCRIPTION

#### A. DIAGNOSTIC COMMANDS

The TC diagnostic commands are listed and explained below. It should be pointed out that the higher commands call the lower ones automatically, for example, by selecting the interrupt test, all of the tests are run on the TC Device.

##### 1) LOOP BACK COMMAND

The Loop Back test checks to see if the loop back test clip is attached and properly connected. If the wiring of the clip is wrong, or if chip L1 located on the 7356 PCB is not a 74368 (refer to ECN #8468 in section 5) errors will result. This test also checks the ability of the 8251 chip to be cleared of command parameters.

## 2) SYNCHRONIZATION COMMAND

Here the ability of the Slave to get into sync is checked by setting the USART for bi-sync mode and 2400 Baud. Two sync characters are sent out, which are received simultaneously via the loop-back connector. If sync is not detected, an error will occur. This test also checks the receiver and transmitter ready lines. The automatic generation of sync characters ability of the 8251 is also tested.

It should be noted here that auto SYNC character generation by the 8251 chip is not totally reliable and occasional errors will occur regardless of overall system integrity. This problem is eliminated in the 8251A. Finally, the overrun error line is tested to be sure that an overrun error will occur when characters are written over one another without reading them in between.

## 3) CLOCK COMMAND

This command checks the TC slave's ability to transmit and receive data. The data is sent out and received via interrupt handlers. A pattern of 256 bytes is transmitted and received, then checked for correctness. Errors will result due to the following conditions: the TC device will not sync properly, a character is not sent when it should have been, a character is not received when expected, or the data is transmitted incorrectly (garbled in transmission).

## 5) INTERRUPT COMMAND

The last test inspects the interrupts in the TC slave to be sure that they go off when they should, and don't when they shouldn't. This is accomplished by setting up the handlers and USART chip, and waiting for the interrupt to occur. Each of the three testable interrupts (receive, transmit, and clock) are checked separately and will give an error if the interrupt did not occur.

## B. TEST RATE SELECTION

The On-Line TC diagnostic has two basic test rates, a single test and a continuous test. After the command is selected, the user is prompted to make a decision on this parameter. Continuous testing is done inside of the TC Command on the Diagnostic Command Processor, and is not associated with the auto-execute ability of the WPS Command Processor.

### 1) SINGLE TEST MODE

If single test mode is chosen, the test is immediately executed once. If the test was successful, a prompt will be displayed to indicate that and a message put up asking if you'd like to run the test again. Hitting execute will run the test one more time, while hitting cancel will end the test. If it failed, the prompt will indicate its failure and show you the error it encountered in the test run.

### 2) CONTINUOUS TEST MODE

The other choice in test rate is continuous mode. Here the test runs continually. When the CANCEL key is struck, the test is terminated, and the user is informed if it was successful or unsuccessful. If successful, the test can be executed again, or it can be canceled. If it failed, a prompt comes up for re-display of the errors.

## C. ERROR COLLECTION MODE

If continuous test rate is chosen, the choice is given to the operator of whether to stop on an error, or save all the errors and display them at the end of the test run. When saving the errors, a maximum of 256 errors can be accumulated.



- TSEM - The TC Semaphore is the main communication link with the command processor. It indicates when a command is to be performed, when to halt a continuous test, and to signal when a test is under execution or completed. A brief summary of codes used in the TSEM is given on the following page.
- TSTATUS - This is an indicator of the status of the TC device. It indicates when an error has occurred (and type) and to indicate when the diagnostic is ready for another command.
- TCMD - This value indicates which test is to be performed. It is to be noted that the higher commands will call the lesser ones first. Thus by running a clock test, a loop-back test and a sync test are also performed.
- TFREQ - This parameter will set the desired clock frequency in such tests that will allow that variable to be user selected.
- TINPUT - The input buffer is pointed to by this variable, it is set aside to be used by the command processor to pass data to the TC diagnostic.
- TOUTPUT - Similarly, the output buffer is pointed to by this address. It is used to pass information to the command processor and is currently used to transmit the error buffer.
- TRATE - This value indicates the rate at which a test is to be performed. At this time, only two basic rates are supported, single test and continuous testing. These codes are also given on the following page.
- TSTOP - The STOP value indicates to the diagnostic package whether to stop on an error or to store them in an error buffer, thus allowing long repetitive testing of a TC device.



TCOUNT - This is a two byte counter to keep track of the number of tests executed in a continuous mode.

F. Communication Codes

TSEM =

'00'	- OK	OK
'80'	- Ready for command	READY
'81'	- System error deleted	SYSFAIL
'82'	- Processing command	INPROG
'83'	- Command completed	DONE
'84'	- Terminate test cycle	STOPPROC
'85'	- Send errors	SENDERRS

TSTATUS =

For Command Processor:

'00'	- Ready	OKSTAT
'XX'	- CMD PROC Not ready	RE-IPL

For return statuses:

'00'	- Successful test	PASS
'01'	- Test failed	FAIL
'02'	- Command not implimented	NOTCMD
'03'	- Zero command	ERRA
'04'	- System failure	SYSFAIL

TCMD =

'00'	- No command	ZEROCMD
'01'	- Fill error buffer	FLERRBUF
'02'	- Loop Back test	LOOPBACK
'03'	- Xmit/Rcv Sync test	SYNC
'04'	- Clock test	CLOCK
'05'	- Transmit/Receive test	XMITRCV
'06'	- Interrupt test	INTERPTS

TFREQ =

'00'	- No clock preference	NOCLOCK
'01'	- 2400 BAUD, Bi-Sync	SY2400
'02'	- 4800 BAUD, Bi-Sync	SY4800
'03'	- 9600 BAUD, Bi-Sync	SY9600

TRATE =

'00'	- One shot test	SINGLE
'01'	- Continuous testing	CONT

TSTOP =

'00'	- Stop on an error	STOPERR
'01'	- Save errors in buffer	SAVEERR

#### G. VARIABLES AND POINTERS

<u>LOCATION</u>	<u>NAME</u>	<u>DESCRIPTION</u>
023B	INBUFPTR	Points to the next place to put a received character.
023D	INBUFCTR	Number of characters received.
023F	OUTBFPTR	Pointer to next character to be sent.
0241	OUTBFCCTR	Number of characters left to be sent.
0243	ERRBFPTR	Pointer to next place for an error code to be placed.
0246	RCVFLAG	Receiver interrupt flag.
0247	CLKFLAG	Clock interrupt flag.
0248	XMITFLAG	Transmit interrupt flag.
0249	CMDWORD	8251 command word.

024A CLKCTR Number of clock interrupts received during the 1  
second interval of the clock test.

1200 ERRCT Number of errors in the buffer.

1201 ERRBUF Start of the error buffer.

1300 INBUF Start of the input buffer.

1600 OUTBUF Start of the output buffer.

#### H. TC ERROR CODES

ERROR 21 Receiving unexpected modem signals.

ERROR 22 Extra modem signals occurring.

ERROR 23 Other than carrier or DSR are on.

ERROR 24 Loop back clip is not attached.

ERROR 25 CTS is not tied to RTS in the clip.

ERROR 26 DSR is incorrectly connected in the clip.

ERROR 27 Carrier not tied to DTR in the clip.

ERROR 28 DSR is not tied to DTR in the clip.

ERROR 29 Carrier and DSR are not tied to DTR in the clip.

ERROR 31 RXRDY is coming on at the wrong time.

ERROR 32 Sync was not detected.

ERROR 33 OE or TX enable does not work.

ERROR 34 TXRDY didn't come on when expected.

ERROR 35 RXRDY didn't get reset.

ERROR 36 Data was incorrectly received.

ERROR 37 Fill characters were not auto-generated.

ERROR 42 Clear clock function is not working.

ERROR 43 Timer cycle is too short.

ERROR 44 Timer cycle is too long.

ERROR 51 A byte of data didnt' get sent.

ERROR 52      A character sent was not received.  
ERROR 53      Data was incorrectly received.  
ERROR 54      Receive Error, some characters not received.

ERROR 61      Receiver interrupt is not working.  
ERROR 62      Transmitter interrupt is not working.  
ERROR 63      Clock interrupt is not working.

I.    DEBUG MONITOR MENU

s)    TRANSMITTER/RECEIVER SYNC TEST  
      CONTINUOUS TEST  
      COLLECT ALL ERRORS

TEST PASSES: 0000

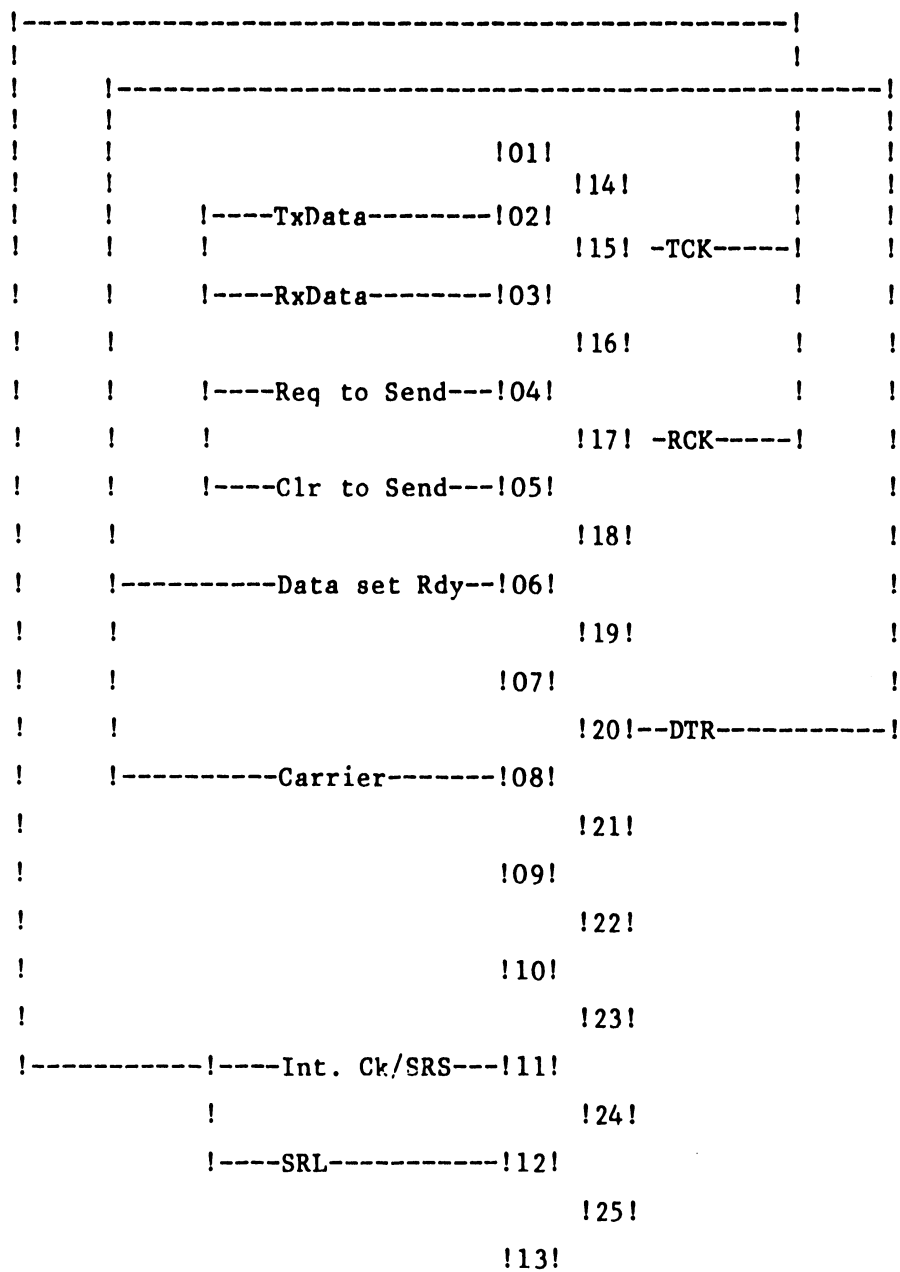
KEY CODES FOR COMMANDS:

l)      LOOP BACK TEST  
s)    TRANSMITTER/RECEIVER SYNC TEST  
c)      CLOCK TEST  
x)    TRANSMIT/RECEIVE TEST  
i)      INTERRUPT TEST

CHOOSE ERROR COLLECTION MODE:  
CONTINUOUS (c) OR SINGLE (s) TEST

12,13,14,15,16,17,18,19,1A,20,21,22,23,24,25,26,27,28,29,2A,30,31,  
32,33,34,35,36,37,38,39,3A,3B,40,41,42,43,44,45,46,47,48,49,4A,4B,  
51,52,53,54,55,56,57,58,59,5A,5B,60,61,62,63,64,65,66,67,68,69,6A,

J. LOOP BACK CLIP CONNECTIONS



It is recommended that the above clip be used in conjunction with the On-Line Telecommunication Diagnostics, but the clip normally used in checking out the 2227B and 2228B TC controllers will work adequately (refer to Service Bulletin # 77 page 66). The jumpers to make on the RS-232 connector are shown above and listed below:

<u>Pin</u>	<u>to</u>	<u>Pin</u>
2		3
4		5
6		8
8		20
11		12
12		15
15		17

K. TC OI-LINE MEMORY MAP

4000	!	!		
	!	!		
	!	!		
	!	!		
	!	!		
	!	!	SCREEN BUFFER	1700
	!	!		
	!	!		
	!	!		
2900	!	!		
	!	!		
	!	!	RESERVED MEMORY	0F00
1A00	!	!		
	!	!		
	!	!	STACK AND VARIABLE SPACE	0100
1900	!	!		
	!	!		
	!	!	OUTPUT BUFFER	0300
1600	!	!		
	!	!		
	!	!	INPUT BUFFER	0300
1300	!	!		
	!	!		
	!	!	ERROR BUFFER	0100
	!	!		
1200	!	!	ERROR COUNT	
	!	!		
	!	!	COMMAND TABLE	0100
1100	!	!		
	!	!		
	!	!	MESSAGE SPACE	0400
0D00	!	!		

	!		!
	!		!
	!	REST OF MAIN SOFTWARE	! 1D00
	!		!
0300	!		!
	!		!
	!	COMMUNICATION AREA (TSEM)	! 0100
	!	-----	!
0280	!	TSEMPTR	!
	!		!
	!	START OF MAIN SOFTWARE	!
0200	!		!
	!		!
	!	TRANSLATION TABLE	! 0100
0100	!		!
	!		!
	!	IPL AND MSEM AREA	! 0100
0000	!		!



## 4.2 ON-LINE SYSTEM CHECKOUT

The suggested method of on-line system checkout (when applicable) for the Communications Controller is a telephone hook-up with a Remote Job Entry (RJE) port with the IBM 370/158 host computer at the Wang Data Center in Burlington, MA (business telephone number (617) 272-8550). The Data Center supports both IBM 2780 and 3780 protocol (connections = 2780, 3780, or 3780c) but will NOT support the protocol used in a WPS connection. An alternate method of on-line checkout is to arrange a test with the Home Office.

### NOTE:

These methods are only to be used if the on-line checkout with the customer's remote site fails.

### RULES FOR USING DATA CENTER FACILITIES

1. the signon procedures and keywords are strictly for customer engineering personnel use only.
2. Under no circumstances the signon or keyword be given to a customer for the protection of data base at the Wang Data Center. Please remember that IBM 370 at Wang Data Center is a time sharing system used by many of its customers.
3. Please limit your on-line checkout time to 10-15 minutes at a time as you may tie up the line for data center customers.
4. Before calling Home Office for assistance, the on-line check must be performed.
5. Successful checkout does insure that you have checked out functioning of hardware, software and modem. It does not checkout any variations in protocols or signon procedure customer may encounter when using other remote host computers.

PROCEDURE:

A. METHOD 1 (QUICK TEST)

1. Prepare two test documents before going on-line with the Data Center. The first document required is a SIGN-ON document which is prepared as follows:

```
For 2780:      /*SIGNON          REMOTE53          SEVXMTKL
                !                !                !
                column 1        column 16        column 28
For 3780:      /*SIGNON          REMOTE46          TBKLDVXA
```

The SIGN-ON document must be prepared exactly as above and must have a /\* in the documents comment field (refer to section 3.5.1).

The second test document is as follows:

```
                /*$ DA
                !
                column 1
```

2. Schedule a TC session using either the 2780, 3780, or 3780c connection and enter first the document ID number of the SIGN-ON document and then document ID number of the other document (refer to section 3.5.2).
3. Dial one of the following telephone numbers of the Data Center depending upon which type of modem the customer has:

<u>MODEM TYPE</u>	<u>SPEED</u>	<u>TELEPHONE NUMBER</u>
201A	2000	(617) 272-9460
201C	2400	(617) 272-6224
208B	4800	(617) 272-4060

4. After the connection is dialed, the modem at the Data Center will automatically answer and present a high pitched answer tone after which you must press the modem's DATA button to enter into the data mode (refer to section 3.5.5).
5. Data transmission must take place now. Observe that RS, CS and CO lamp indicator do indicate transmission activity.
6. After the two documents have been successfully transmitted, the computer will transmit to your system a listing of the computer's JOB queue. The reception of this file indicates that your system, including modem, is functional. An example is the following file:

```
$11.28.42 JOB 4460 WO$5KMM ON RM14.RD1 PRIO 15
$11.28.42 JOB 4466 WN@5KMQL ON INTRDR1 PRIO 15
$11.28.42 JOB 4379 WN@5KLFH ON RM14.PR1 PRIO 15
$11.28.42 JOB 4374 DT#5KLDM ON PRINTER1 PRIO 15
$11.28.42 JOB 4406 KE$5KLWB ON RM33.PR1 PRIO 15
$11.28.42 JOB 4381 BE@5KLG M ON RM7.PR1 PRIO 15
$11.28.42 JOB 4408 UD@5KLWJ ON PRINTER2 PRIO 9
$11.28.42 JOB 4313 WN@5KKL7 EXECUTING E PRIO 8
$11.28.42 JOB 4341 WN@5KK3J EXECUTING E PRIO 6
$11.28.42 JOB 4363 WC@5KLAY EXECUTING D PRIO 6
$11.28.42 JOB 4450 MS@5KMJA EXECUTING D PRIO 6
$11.28.42 JOB 4242 CR@5KJGL EXECUTING B PRIO 2
$11.28.42 JOB 4413 HD@5KLX4 EXECUTING A PRIO 2
$11.28.42 JOB 4431 WC@5KL98 EXECUTING D PRIO 2
```

7. If no file is received in few minutes, check the communication session summary. If it indicates session is ABORTED then disconnect the line and re-start the procedure at step 2. After several retries if you are not successful then call Home Office to do a on-line check.

B. METHOD 2 (LONG TEST)

1. Prepare SIGN-ON document as shown in step 1 of Method 1.
2. The second document must be prepared using exactly following JCL (job card language) data.

```
Column 1                               29
//W33 JOB RAV,PRTY=8,CLASS=A
/* ROUTE PRINT REMOTE53                 (or REMOTE 46)
// EXEC PGM=IEBGENER
//SYSPRINT DD SYSOUT=A
//SYSIN DD DUMMY
//SYSUT2 DD SYSOUT=A
//SYSUT1 DD *
```

3. The third document must be your test document. (It can be any one of the short documents on WP system).
4. Schedule a TC session and enter first the document ID of SIGNON document then JCL document ID and third your test document ID.
5. Follow instructions in steps 3, 4, and 5 of section A.
- 6\* After the three documents have been successfully transmitted, the computer within 5 to 10 minutes will transmit to your system the test document you prepared in step 3. With this document computer will also send job statistics as well as notices for users. The reception indicates that you have functional hardware, modem, and telephone lines.

\*NOTE:

Depending on the time of the day computer may take more than 10 minutes to process your job and sending your data. In that case after say 5 minutes you can disconnect the telephone line, and wait 20 minutes or so before re-dialing. Before you redial the computer you must schedule another session specifying document ID for SIGN-ON document only. If your

job is ready computer will send you the test document. It is also possible that if someone else dials the computer with same SIGN-ON while you are waiting (not signed on), he will receive your test document.

#### 4.3 LINE MONITOR TESTER

##### 4.3.1 INTRODUCTION

The telecommunications line monitor tester (W.L. #190-0701) does not test any hardware or software by itself. It is designed to display the Hex Code responses transmitted or received from the local and remote terminal on a CRT. In most of the installation problems it is imperative to know why the system is not signed on to the remote terminal. It could be that SIGN-ON data is not entered correctly or the remote terminal is dead. The person using this tester must be familiar with particular communications protocol being used and by analyzing responses from the remote terminal he should be able to determine the problem. Please substitute any reference to 2200 System by WP Telecom when this tester is used on a WP system.

##### 4.3.2 DESCRIPTION

The line monitor tester was designed primarily to assist on installations. The tester uses 8 LEDs to indicate modem status; it also interfaces the data bus to a remote CRT allowing a visual display of data transmitted and data received. This tester has two modes of operation:

1. 2200 to Modem-In this mode the test unit is inserted in the communications line and allows monitoring of the transmission line and indicates modem status conditions. In this mode the 2200 is communicating with either a terminal or a computer, through a MODEM which provides all signals and status conditions necessary for proper operation.

2. 2200 to 2200 - In this mode the test unit is again inserted in the communications line to perform the same function as mentioned in #1. In this mode the 2200 is communicating with another 2200 through a direct cable connection. Thus, all clocks are self-generated and status is maintained by the tester. In essence, the tester is acting as a null modem. The advantage of having this mode is primarily in insulating problems by elimination of system components (by eliminating the modem it can be determined if the communications controller is working properly). It also enables the system to be tested at a local level to insure that the controller boards are operational.

#### 4.3.3 OPERATION

The tester requires AC power (115V 50/60 Hz or 230V 50 Hz). It also requires the following materials to operate properly:

- (1) TC cable (W.L. #220-0113).
- (2) 1 spare 2200 System CRT controller (W.L. #212-2216).
- (3) 1 spare CRT (if item 3 is not available the CRT in the system can be used).

1. Controls - There are four control switches on the tester.

They are:

- (a) Power On/Off - controls AC power.
- (b) Reset - This returns the cursor to the upper left and clears the screen of the monitor CRT.
- (c) Mode Selection - This selects either 2200 to 2200 mode or Modem to 2200 mode.
- (d) Baud Selection - This selects the bit transmission rate (2400 baud or 4800 baud). It is operational only in the 2200 to 2200 mode. (Does not apply to asynchronous communications controllers.)

2. Interconnections (all connections are made with power off).

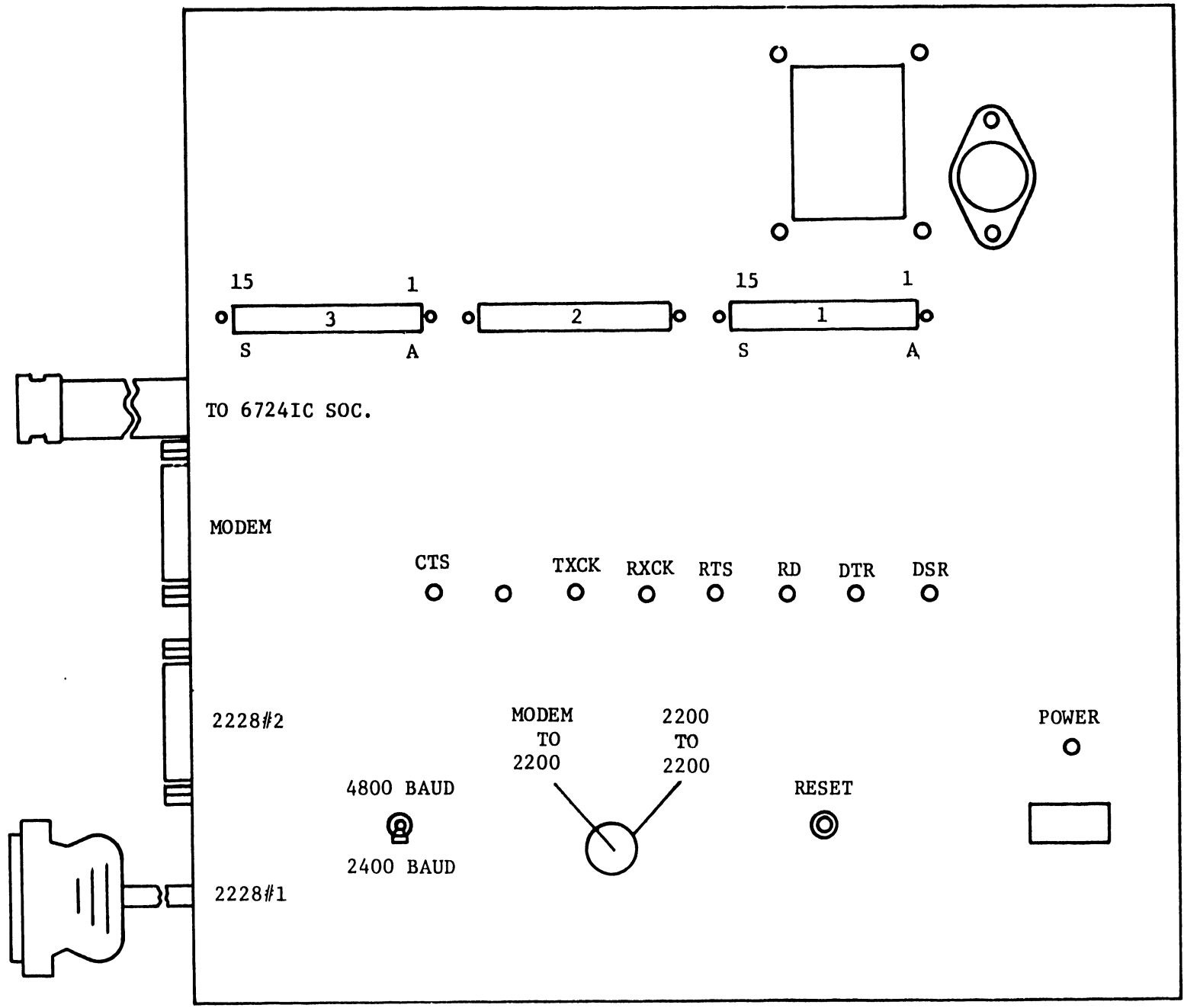
- (a) Plug in the CRT controller board and connect the spare CRT to the controller board. (See Figures 4-1 and 4-2)
- (b) 2200 to Modem - In this mode of operation the cable labeled 2228 #1 connects to the communications controller board; connect the cable supplied with the system to the modem, connect the other end of this cable to the tester connector labeled MODEM. Now connect the ribbon cable to the following PC board through the 16 pin IC socket provided on that PC board:

2227B	6730
2228	6724
2228B	7224
Option 62	7153
Option 62B	7153-1
WP TC Option	Conn. J1 on 7355

Apply power to the system, the CRT and the test unit. The tester should indicate modem status through the LEDs and when transmission begins, all information transmitted or received can be observed on the CRT in hexadecimal form (Refer to Tables 4-1 and 3-3 to decode the transmission).

- (c) 2200 to 2200 - The cable labeled 2228 #1 connects to a communications controller board in one of the available systems. The second cable now connects to a second system through another communications controller and plugs into the tester connector labeled 2228 #2. All other connections remain the same. Apply power; operation is the same as through a modem. The one difference in this mode is that the baud select switch is operational, thus, a transmission rate of either 2400 or 4800 baud is available for a bi-sync communications controller.

FIGURE 4.1 LINE MONITOR TEST





4-27

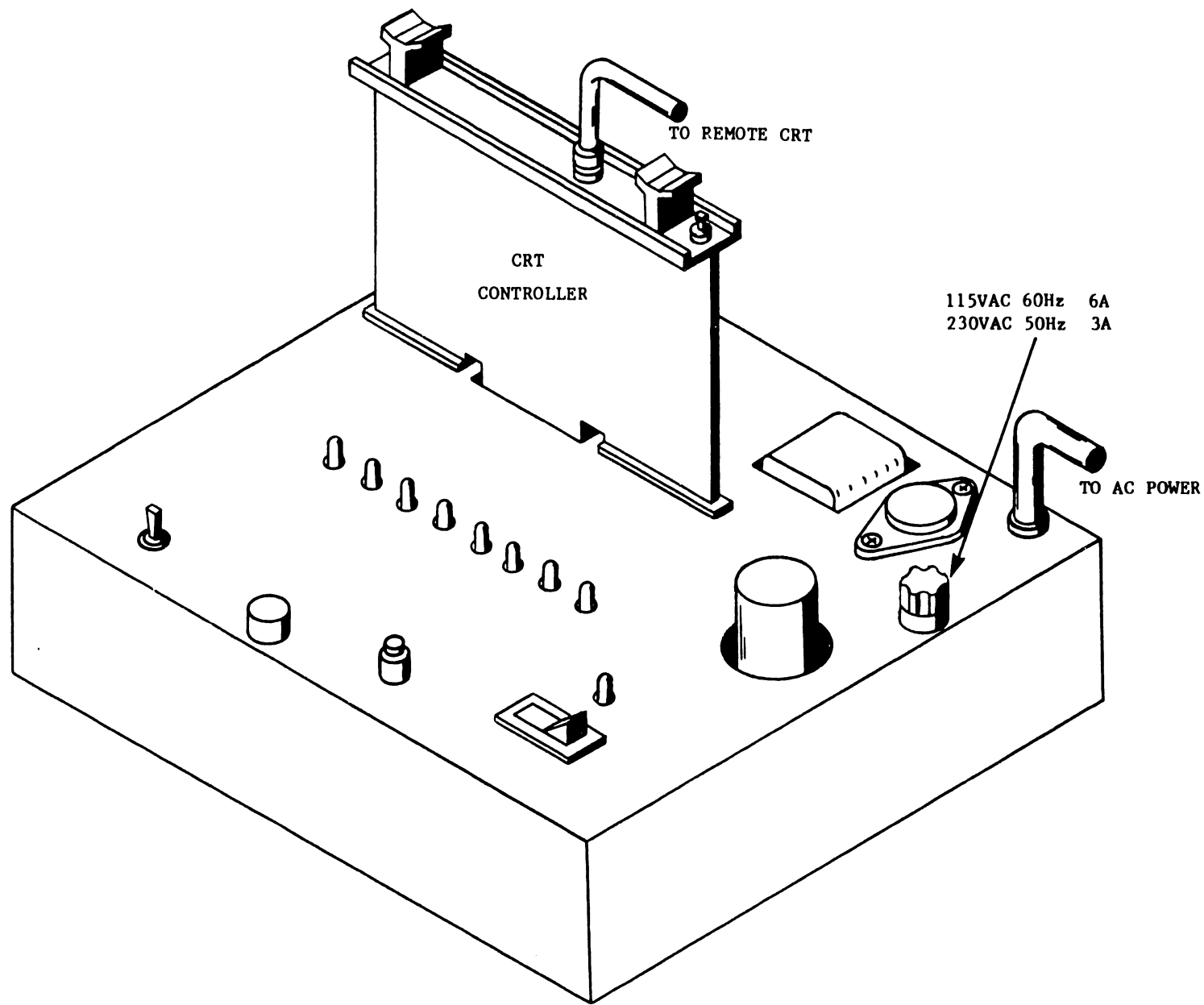


FIGURE 4.2 LINE MONITOR TESTER

TABLE 4-1  
CHARACTER CONVERSION

<u>DATA LINK CONTROL CHARACTER</u>	<u>EBCDIC</u>	<u>HEX</u>	<u>USASCII</u>	<u>HEX</u>
ENQ	ENQ	2D	ENQ	05
ETB	EOB	26	ETB	17
ACK 0	DLE "70"	1070	DLE0	1030
ACK 1	DLE /	1061	DLE1	1031
ITB	IUS	1F	US	1F
WACK	DLE,	106B	DLE;	103B
RV1	DLE@	107C	DLE	103C
TTD	STX ENQ	022D	STX ENQ	0205
STX	STX	02	STX	02
EOT	EOT	37	EOT	04
SYN	SYN	32	SYN	16
ETX	ETX	03	ETX	03
NAK	NAK	3D	NAK	15
EM	EM	19	EM	19
HT	HT	05	HT	09

NOTE:

EBCDIC code used by WP 2780/3780 Emulators.

4.3.4 HOW TO TROUBLESHOOT THE SYSTEM USING THE LINE MONITOR

1. When system is signed-on to the remote end, watch for response from remote end to the inquiry message. If no reply, then remote end either does not recognize the message because of poor line connection, marginal modem at either end or bad modem. Try dialing again a few more times.
  
2. Check the modem status when transmitting. RTS and CTS must be on when transmitting. DTR and DSR must be on after telephone connection is established and must remain on during entire period of transmission.
  - (a) When receiving CO light must be ON.
  - (b) T<sub>x</sub>C light must be on all the time (for bi-sync communications only).
  - (c) R<sub>x</sub>C light must be on during receiving data (for bi-sync communications only).

NOTE:

The address for the CRT controller board remains 005.

3. Typical bi-sync message displayed on the CRT.

- 32 32 32 32 2D FF - System sending a inquiry or a bid to the remote terminal.
- 32 32 10 70 FF - Remote terminal acknowledges system inquiry (ACK0).
- 32 32 32 32 02-DATA-03 - - FF - Data transmitted to a remote terminal.
- 32 32 10 61 FF - Remote terminal acknowledges systems transmission (ACK1).
- 32 32 32 32 37 FF - Systems sends end of transmission (EOT) code to remote terminal.

## 4.4 GENERAL SYSTEM TROUBLESHOOTING HINTS

### 4.4.1 INTRODUCTION

Troubleshooting the telecommunications system is a very complex task. There are so many factors and components involved, such as telephone lines, modems, host computers. Any one of these can cause a problem. The problem is not always a hardware failure in any of the components. More than 70% of the problems encountered in the telecommunications system at installation time are not sufficient information for sign-on procedure, wrong options on the modem and poor knowledge of operating procedure.

### 4.4.2 TROUBLESHOOTING CHECKLIST

The first thing any service representative should do is to check the installation items as stated below.

- a) Check the entire WP system by running all possible diagnostics available and checking all voltages.
- b) Check the telecommunications processor for correct address, visually inspect the cards for any broken components, short etches, etc. Make sure the cards are seated properly in connectors.
- c) Run the off-line diagnostic if available. Most of the hardware functions are checked by the diagnostic.
- d) Check the T.C. cable for any bad contacts. Do a continuity check on the cable from one end to another end and make sure all the required signal wires are connected on both ends of the cable.
- e) Call the Telephone Data Service Center and have the modem checked. If possible be present when the modem service representative arrives and show him the problem.
- f) Make sure the host computer can, in fact, support the Wang system. For example, host computer can support only single record blocks, in that case change in the Wang Software is required to accomodate host computer compatibility.

- g) Get in touch with data processing personnel at the host computer and discuss the sign-on procedure and explain the problem. Almost all of the sign-on type problems can be resolved this way. If you know anyone else using the same host computer or similar system, find out how he is using it.
- h) Most important of all, try to get help from your Area office, program analyst, Home Office, or anyone you know who has a telecommunications background.

#### 4.4.3 MODEM CONTROL SIGNALS CHECKOUT

If the modem is suspected of causing trouble, the following control signals can be checked using an oscilloscope. The modem must be in the data mode when checking the control signals.

- 1) Place the 7356 PCB on an extender or use the EIA Interface Test Set (refer to section 4.6) so that you have access to signals used by the RS-232 connector (25 pin Cannon connector). Signal pin numbers given below are in reference to 25 pin Cannon connector.

- 2) Pins 1 and 7 are chassis and reference ground.

Check for any noise on ground circuit.

- 3) Pin 2 TRANSMITTED DATA (TO data set).

Signals on this circuit are generated by data terminal equipment. Check to see if terminal is transmitting data when in transmit mode. The data terminal will not transmit data unless clear-to-send signal is ON (+3v to +25v) on pin 5, data terminal ready signal is ON (+3v to +25v) on pin 20 and data set terminal ready signal is ON (+3v to +25v) on pin 6.

- 4) Pin 3 RECEIVED DATA (FROM data set).

Signals on this circuit are generated by receiving data set in response to data signals received from a remote data set. This circuit is always held in the MARK state (-3v to -25v) when the received line signal detector (pin 8) is OFF (-3v to -25v).

- 5) Pin 4 REQUEST-TO-SEND (TO data set).

Data terminal presents ON signal (+3v to +25v) on this circuit when terminal intends to transmit data. After turning this signal ON, data terminal must wait for ON condition to clear-to-send (pin 5) circuit before starting data transmission.

- 6) Pin 5 CLEAR-TO-SEND (FROM data set).

Signal on this circuit is generated by data set to indicate whether or not data set is ready to transmit data. This circuit is turned ON (+3v to +25v) in response to ON signal on pin 4 delayed approximately 50 to 200 ms depending on type of modem and customer options selected.

- 7) Pin 6 DATA SET READY (FROM data set).

The ON condition (+3v to +25v) on this circuit indicates that data set is in DATA mode and is capable of receiving and transmitting data. The data terminal ready signal on pin 20 must be ON (+3v to +25v) during DATA mode. The OFF condition (-3v to -25v) indicates that data set is Talk, Test, or On-Hook mode.

8) Pin 8 RECEIVED LINE SIGNAL DETECTOR (carrier) (FROM data set).

The ON condition (+3v to +25v) on this circuit indicates the presence of the data carrier signal above the receiver threshold for at least  $47+3$  milliseconds. This circuit is ON during receive mode and will turn OFF (-3v to -25v) and disable receiver when data terminal is in transmit mode or when request-to-send signal is turned ON.

9) Pin 15 TRANSMITTER SIGNAL ELEMENT TIMING (FROM data set).

The square wave signals on this circuit at 2000 HZ (for 2000 baud modem) or 2400 HZ (for 2400 baud modem) or 4800 HZ (for 4800 baud modem) are used to provide the data terminal equipment with signal element timing information for the transmitted data circuit. A timing signal will be present on this circuit at all times when power is on in the data set.

10) Pin 17 RECEIVER SIGNAL ELEMENT TIMING (FROM data set).

The square wave signal on this circuit at 2000 HZ (2000 baud modem) or 2400 HZ (2400 baud modem) or 4800 HZ (4800 baud modem) rate is used to provide the data terminal equipment with receiver signal element timing information. The transition from ON to OFF normally indicates the center of each signal element on the received data circuit. A timing signal will be present on this circuit when CARRIER (pin 8) is ON for data sets 201A and 201C.

11) Pin 20 DATA TERMINAL READY (TO data set).

The data terminal must apply an ON condition (+3v to +25v) on this circuit at all times to go into the DATA mode. An OFF signal on this line will not allow data set to go in the data mode. An OFF signal on this line during data transmission/reception will make data set drop the communication line.

4.4.4 MODEM SELF TESTS

Several manufacturers including Bell Telephone have the self loopback test or any other kind of test built into their modem. Before calling the Telephone company or manufacturer, please use these self tests. Test procedures are always given in the modem operating manual. The Bell 201C and 208B data sets which have self tests and instructions to run them are given below.

4.4.4.1 DATA SET 201C SELF TESTS

BUTTONS ON THE DATA SET

Five buttons are located on the front panel of the data set.

The functions of the buttons are as follows:

RO (Receive Only) - Used when testing the data set to condition it locally as a receiver.

AL (Analog Loopback) - Connects the output of the local transmitter to the input of the local receiver.

ST (Self Test) - When depressed this button causes the data set transmitter to turn on and transmit fixed pattern.



RT (Remote Test) - When depressed, this button conditions the data set to be tested remotely from a Telephone Company Data Test Center.

DL (Digital Loopback) - This button allows for digital loopback test on a 4 wire data set.

#### STATUS LAMPS ON THE DATA SET

The data set is provided with eight status lamps. Each lamp lights a portion of the front panel which shows the name of the control lead being monitored. The lamps and their functions are as follows:

ON lamp - This lights when the power cord is plugged into a 105- to 130-volt ac source.

TR (Terminal Ready) - This lamp monitors the status of the data terminal ready signal on the customer interface. When the lamp is lighted, the signal is in the on condition and tells the data set that the terminal is ready for data communication.

MR (Modem Ready) - This lamp monitors the status of the data set ready signal on the customer interface. When the lamp is lighted, the signal is in the on condition and the data set is ready for data communication.

RS (Request-to-Send) - This lamp indicates the status of the request-to-send signal on the customer interface or from the internal circuits which check the data set. When the lamp is lighted, the request-to-send signal is in the on condition and tells the data set to be conditioned to transmit data. In normal operation, when the CO lamp is on, the RS lamp will be off regardless of the status of the RS signal at the customer interface.

CS (Clear-to-Send) - This lamp monitors the status of the clear-to-send signal on the customer interface during both normal and test modes of operation. When the lamp is lighted, the signal is in the on condition and the data set is ready to transmit data.

CO (Carrier On) - This lamp monitors the status of the carrier on signal on the customer interface during both normal and test modes of operation. The lamp comes on when a signal is being received by the data set.

MC (Modem Check) - The MC lamp indicates the absence of the receiver signal timing (pin 17) signal at the customer interface. In normal operation, the lamp will be ON when the CO lamp is OFF. It will be OFF when the CO lamp and interface signal CF (pin 8) are ON. When using the self-test feature, the MC lamp is ON whenever CO is OFF. However, when CO is ON during self-test, the MC flashes ON whenever an error occurs on the received data lead.

TM (Test Mode) - This lamp will light when the data set is placed in the test mode by use of the AL, ST, RT or DL test switches.

## TESTING

Perform an analog loop-back self-test with a data set at each end. If either set fails, replace it with one known to be operating properly.

If both data sets pass the analog loop-back self-test, perform the end-to-end self-test (2-wire sets).

### ANALOG LOOP-BACK SELF TEST (2-WIRE OR 4-WIRE DATA SETS)

1. Depress the AL and ST switches.

Requirement: All lamps except MC are lighted during a 30-second testing interval. If the MC lamp blinks or

remains steadily ON, or if any of the other lamps are extinguished, the data set is defective and should be replaced.

2. Depress the RO switch.

Requirement: RS and CS lamps extinguish. MC lamp lights. CO lamp extinguishes if data set optioned for switched carrier operation (options XA, XD, or XE).

3. Return the data set to normal operation by depressing the RO, ST, and AL switches.

Requirement: Switches return to the out position and TM lamp extinguishes.

#### END-TO-END SELF-TEST (2-WIRE DATA SET)

1. Depress ST switch at both ends.

Requirement: TM lamp lights.

2. Depress RO switch at receive ends.
3. Establish line connection.

Requirement: At transmit end, all lamps are lighted except CO lamp. At receive end, all lamps are lighted except RS, CS, and MC lamps. If MC lamp blinks an average or more than twice per minute or remains steadily ON, the data set or telephone facility is the source of trouble.

4. Repeat the test in the opposite direction by releasing the RO switch at one end and depressing the RO switch at the other end.
5. Return to pretest mode by releasing the ST switches at both ends and releasing the RO switch at the receive end.

Requirement: TM lamp extinguishes.

#### 4.4.4.2 DATA SET 208B SELF TESTS

##### BUTTONS ON THE DATA SET

Six buttons are located on the front panel of the data set. All of these except the LP button are push-to-operate, push-to-release type. The functions of the buttons are as follows:

LP (Lamp Test) - When depressed, this button causes all of the lamps to light except the ON lamp.\* This button is used to determine if all the status lamps are functional. Its use does not affect other data set operations.

\* The ON lamp is normally lighted when power is applied.

AL (Analog Loopback) - Connects the output of the local transmitter to the input of the local receiver. Depressing the AL button prevents the data set from entering the data mode from the talk mode or upon automatic answer. While the talk mode is not inhibited and calls can be made with the telephone set, any attempt to transfer to the data mode will result in the line being disconnected if the AL button is depressed.

ST (Self Test) - When depressed, this button causes the data set transmitter to turn on and transmit a fixed pattern. The receiver is conditioned to look for this pattern and generate a signal which causes the ER lamp to flash if an error is detected.

RO (Receive Only) - Used when testing the data set to condition it locally as a receiver. When depressed, the switch internally conditions the request-to-send signal to off regardless of the state of the request-to-send signal from the terminal equipment or from other test buttons.

RT (Remote Test) - When depressed, this button conditions the data set to be tested remotely from a Telephone Company Data Test Center (DTC).

50 Button - When depressed, this button provides a request-to-send/clear-to-send interval of 50 millisecond (ms). When the button is released, the request-to-send/clear-to-send interval is 150-ms. In almost all cases, the 50-ms request-to-send/ clear-to-send interval can be used (button depressed). The 150-ms request-to-send/clear-to-send interval (button released) is provided to assure terminal compatibility and for applications where the channel delay exceeds the length of the transmitted signal. If the terminal equipment experiences frequency time-outs, the 150-ms request-to-send/clear-to send interval might correct the condition.

## STATUS LAMPS ON THE DATA SET

The data set is provided with seven status lamps. Each lamp lights a portion of the front panel which shows the name of the control lead being monitored. The lamps and their functions are as follows:

ON Lamp - This lights when the power cord is plugged into a 105- to 130-volt ac source.

TR (Terminal Ready) - This lamp monitors the status of the data terminal ready signal on the customer interface. When the lamp is lighted, the signal is in the on condition and tells the data set that the terminal is ready for data communication.

MR (Modem Ready) - This lamp monitors the status of the data set ready signal on the customer interface. When the lamp is lighted, the signal is in the on condition and the data set is ready for data communication.

RS (Request-to-Send) - This lamp indicates the status of the request-to-send on the customer interface or from the internal circuits which check the data set. When the lamp is lighted, the request-to-send signal is in the on condition and tells the data set to be conditioned to transmit data. In normal operation, when the CO lamp is on, the RS lamp will be off regardless of the status of the RS signal at the customer interface.

CS (Clear-to-Send) - This lamp monitors the status of the clear-to-send signal on the customer interface during both the normal and test modes of operation. When the lamp is lighted, the signal is in the on condition and the data set is ready to transmit data.

CO (Carrier ON) - This lamp monitors the status of the carrier on signal on the customer interface during both normal and test modes of operation. The lamp comes on when a signal is being received by the data set.

ER (Equalizer Retrain) - This lamp monitors the status of the automatic retrain mode. If the CO lamp is lighted and the ER indicator is blinking, it indicates that invalid data has been received and that the automatic equalizer is now retraining. Continuous blinking, while the CO lamp is on, is an indication of marginal performance. When the data set is in the ST mode, the ER lamp blinks when an error is detected in received data. For normal operation, when the CO lamp is off, the ER lamp should be lighted and, when the CO lamp is lighted, the ER lamp should be off. Thus, CO and ER lamps light alternately in normal operation. A lighted ER lamp indicates an abnormal condition only when the CO lamp is also lighted.

#### DATAPHONE TESTING

In cases of suspected trouble, the attendant should perform the Lamp Check, the Analog Loopback Test, test the data terminal equipment, and perform an End-to-End Self Test before calling the Telephone Company to report trouble. Only if these checks indicate trouble in Telephone Company provided equipment should the problem be reported to the Telephone Company.

In addition to the following tests, the Telephone Company Test Center personnel may request further assistance in trouble isolation by use of built-in features

#### LAMP TEST

Depress the LP nonlocking button. All the lamps on the data set should be lighted. The LP button can be depressed at any time since it does not affect normal data set operation.

## ANALOG LOOPBACK SELF TEST

The Analog Loopback Self Test is performed to analyze the data set without using external equipment. The test is performed as follows:

Check that the data set is idle and that power is applied.

1. Depress AL button.
2. Depress ST button.

Check that the ON, RS, CS and CO lamps are on and that ER and MR lamps are off. Disregard the status of the TR lamp. If the lamps are not as indicated, the data set has failed the Analog Loopback Self Test.

3. Observe the ER lamp for 30 seconds.

If the ER lamp is on or blinks, this indicates that the data set has failed the Analog Loopback Self Test.

At the end of the test:

4. Depress the AL and ST buttons.

The data set is returned to the normal operating condition.

### NOTE:

The data set power supply is equipped with an over-voltage protection circuit which limits the output voltage as it rises excessively. If this occurs, the data set will fail the Analog Loopback Self Test. To reset the power supply, the power cord must be unplugged and replugged into the ac outlet. If the data set still fails the Analog Loopback Self Test, notify the Telephone Company Repair Service for correction of the problem.



## END-TO-END SELF TEST

The End-to-End Self Test is performed to test both far-end and near-end data sets and the telephone channel between the two sets. The test is performed as follows:

1. Place a call to the far end and arrange to perform the End-to-End Self Test. Discuss the duration of the test (at least 5 minutes) and when to return to the talk mode.

Request the far end to check the following lamps after the far-end data set has been transferred to the data mode. (ON, RS, CS, and ER lamps are on; MR and CO lamps are off; disregard status of TR lamp.) If the lamps are not as indicated, the system has failed the End-to-End Self Test.

2. Request the far end to depress the ST button on the data set and the DATA button on the telephone set.

The far-end data set is now transferred to the data mode.

3. Depress the ST and RO buttons on your data set and then depress the DATA button on the telephone set.

Your data is now transferred to the data mode and it is possible to receive data.

Check that the ON and CO lamps are on at your data set and that the RS, CS, MR, and ER lamps are off. Disregard status of the TR lamp. If the lamps are not as indicated after transferring to the data mode, the system has failed the End-to-End Self Test.

Observe the ER lamp for a 5-minute period. The ER lamp should be off and should not blink more than an average of three times in any 1-minute period.

4. After the prearrange time, return to the talk mode and discuss the results of the test.
5. Repeat the test in the opposite direction by releasing the RO button on your data set. Request the far end to depress the RO button on that set.

Request the far end to check the following lamps after both data sets have been transferred to the data mode. (ON and CO lamps are on; RS, CS, MR, and ER lamps are off; disregard status of TR lamp.) If the lamps are not as indicated, the system has failed the End-to-End Self Test.

6. Return both data sets to data mode by depressing DATA buttons on the telephone sets at both locations.

Check that the ON, RS, CS, and ER lamps are on at your data set and that the MR and CO lamps are off. Disregard status of TR lamp. After transferring to the data mode, if the lamps are not as indicated, the system has failed the End-to-End Self Test.

7. Repeat the 5-minute check for this direction of transmission; then return to talk mode.

After the 5-minute check has been performed and the results have been discussed, return the data sets to normal operation as follows:

8. Release the ST button at your data set.

Data set is returned to normal operation.

9. Request the far end to release the ST and RO buttons.

Far-end data set is returned to normal operation.

NOTE:

If tests fail, make another attempt before reporting trouble by establishing a new connection.

#### 4.5 TC SOFTWARE AND TROUBLESHOOTING PROCEDURE

The following troubleshooting procedures can be used after general troubleshooting techniques fail to resolve the problem. Refer to section 3.10 for software module details.

##### 4.5.1 TC FAILS TO OPERATE

If TC does not seem to operate (e.g., will not cancel or initiate a session):

1. Display page 21 of TC Memory. If it is all zero, or has bad parity, the IPL sector has not executed properly. Check that the TC slave is turned on. Sometimes IPL doesn't work - try it again. This may also indicate a bad master.
2. If page 21 seems OK, check page 26. Byte 0A identifies the occupying module:

FF - QDIPL. If this module is in memory, the IPL procedure has not completed properly. Check page 00, byte 08 (PSTAT, refer to TM02). It will be either FE (indicating a disk error) or FD (indicating a failure to match the port identification hardware switches against the PORTID field of the QCB). If there is a disk error, the MSEM area (pointed to by bytes 04-05 of page 00) will show the details, just as for the WP system (refer to TM02). If there is a PORTID mismatch, check the QCB and the switches. If the QCB has been destroyed, a system IPL will reinitialize it. However, this should never happen, and should be considered a serious bug if it does.

00 - QD INIT. If this module is in memory, TC is waiting for a Start from the Master. If there is a session queued, something has gone awry - either a disk error or a software bug. Check page 00, byte 08 for a disk error as above. If its a software bug, re-IPLing the TC slave will start the queued session. It can then be cancelled if you wish.

10 - BD ESTAB. If this module is in memory, TC is waiting for Data Set Ready. Check the equipment to determine the problem.

40 - BD Main. The only time this module remains in memory indefinitely is when there has been a disk error. Check as described above.

41 - BD Recv. We should be in Control Receive or Receive State. Display page 1F (the BCB) to determine which:

Byte F0 = 03 - Control Receive (waiting to receive)  
Byte F0 = 01 - Receive

42 - BD Send. We should be in Control Send or Send State. Display page 1F (the BCB) to determine which:

Byte F0 = 04 - Control Send (Bid)  
Byte F0 = 02 - Send

If you suspect something amiss in the session just completed, display page 1F (the BCB). Byte F0 shows line status at the end of session:

0F - EOT - this is a normal completion or Session was cancelled  
08 - Line Dropped  
09 - Retries failed  
0A - Logic (software) bug

#### 4.5.2 ABORTED SESSIONS

If a Session is aborted before completion, you can find out what happened to it by examining the SCB. First display the QCB and then chain through the abort list until you find the SCB with the Session ID your are interested in.

Byte 90 gives the Line State at the end of the session: (These are the same values as in the BCB byte F0 at session completion).

- 08 - line dropped
- 09 - retries failed
- 0A - logic error (software bug)

The SCB also shows which documents had been sent when the session was aborted. For each document in the list, the DOCSSENT byte is 01 if the document has been sent, 00 otherwise. However, the DOCSSENT byte is never set to 01 for sign-on documents, since these documents are re-sent if the session is restarted.

#### 4.6 EIA INTERFACE TEST SET

The ITS 1 EIA Interface Test Set is a self-contained pocket size test set that can be inserted between the Data Communication Equipment (DCE) or modem and Data Terminal Equipment (DTE). It permits the user to monitor the EIA RS-232 signals and isolate and identify sources of trouble.

The ITS 1 contains nine indicators which continuously monitor the level of the following interface signals: transmitted data, received data, request to send, clear to send, data set ready, received carrier detect, data terminal ready, signal quality detect and ring indicator. Two indicators monitor the transmit and receive clock signals. Unlike the nine levels indicators, these two indicators will not respond when only a DC level is present. The clock interface signal indicators will only turn on when there is an active clock signal present. Two additional uncommitted indicators are available for monitoring either positive or negative levels on any of the interface lines.

The ITS 1 contains 24 switches which allow any of the interface signals except line one, (Frame Ground) to be interrupted. These switches are physically located in the center of the front panel and functionally divide the Test Set into two halves. The upper half contains a cable and connector for connecting the Test set to the DCE or modem. The indicators which monitor signals originating from the modem are also located on the upper half of the front panel. Likewise, the lower half of the Test Set contains a connector to which the DTE (terminal or CPU) can be connected and the indicators which monitor signals originating from the DTE. The positive and negative test indicators are also located on the lower half of the Test Set. All indicators are labeled with both the standard EIA designation and the commonly used abbreviations.

Twenty five pins are located both above and below the switches. These pins permit monitoring of any of the interface lines with either or both the positive and negative test indicators with jumpers supplied or probing with an external meter or oscilloscope. Both sets of pins are arranged in the same configuration and order as the pins in a standard EIA RS-232 female connector.

The ITS 1 is housed in a sturdy plastic case with aluminum extrusions and hinge. A positive latch is provided on the cover to keep the Test Set closed securely when not in use. The front panel is photographically etched and overcoated to prevent the lettering from being scratched or marred during use. The Test Set is self-contained and is powered by two penlite batteries which will provide over 100 hours of continuous operation. No power is consumed by the Test Set when not in use.

SPECIFICATIONS

LEVEL INDICATORS	ACTIVITY INDICATORS.....	transmit clock
Transmitted Data		Receive Clock
Received Data	INDICATOR THRESHOLD.....	+ 3 volts
Request to Send	INDICATOR INPUT IMPENDANCE.....	30,000 ohms
Clear to Send	POWER.....	Two 1.5 volts
Data Set Ready		AA Batteries
Received Carrier	DIMENSIONS.....	5.5"L x 3.6"W
Detect		1.6"H
Data Terminal Ready	WEIGHT.....	12 oz.
Signal Quality Detect		
Ring Indicator		
Positive Test		
Negative Test		

TYPICAL APPLICATIONS

(DTE)		
TERMINAL		ITS 1
OR CPU		

(DCE)		
MODEM		ITS 1

(DTE)		(DCE)
TERMINAL	ITS 1	MODEM
OR CPU		

**5**

**ENGIN-  
EERING  
CHANGE  
NOTICES  
(ECN'S)**



5. ENGINEERING CHANGE NOTICES C.E.C.N.'s

The Model 5528 communications controller is comprised of the following P.C.B's:

210-7353	TC DATA LINK BOARD
210-7354	MEMORY BOARD
210-7355	CPU BOARD
210-7356	MODEM & ACU INTERFACE BOARD
210-7357	CURRENT LOOP INTERFACE BOARD
210-7358	TCP REGULATOR BOARD
210-7359	TCP MOTHERBOARD

The following is a "TO BE EXECUTED" ECN listing with the electronic revision levels (E-REV) for the associated TC P.C.B.'s:

<u>P.C.B. #</u>	<u>ECN</u>	<u>DESCRIPTION</u>
7353	0	None
7354	0	None
7355	8184	Artwork/Schematic/Design change
	1	
		1) Add wire jumper from connector 5 pin J to <u>+</u> OV.
		2) Add wire jumper from connector 5 pin L to L1-6 ( <u>out</u> ).

REASON FOR CHANGE

To make unit testable using 928 debug monitor.

<u>P.C.B. #</u>	<u>ECN</u>	<u>DESCRIPTION</u>
7356	7836 1	Artwork>Loading Sketch/Schematic/ Design change (see figure)
		1) Add (1) 74LS00 IC (WL#376-0207)
		2) Add (2) 180 ohm 1/4W Resistors (WL#330-2018)
		3) Add wire jumper from L12-2 to L12-15 (+5VR)

REASON FOR CHANGE

To add Busy and Power-On indicator LED's.

7356	7836A 2	Artwork>Loading Sketch/Schematic/ Design change (see figure)
		1) Add (1) .01 uf 25V Cer Cap (WL #300-1903)
		2) Add (1) 68 ohm 1/4W Res (WL #330-1068)
		3) Add (2) 120 ohm 1/2W Res (WL #331-2012)
		4) Add (1) MPS 6512 Transistor (WL#375-1012)
		5) Add (1) MPS 6518 Transistor (WL#375-1014)

REASON FOR CHANGE

To support Bisync 2228N Null Modem operation.

NOTE: This ECN is required for use with 2228N Null Modem.

<u>P.C.B. #</u>	<u>ECN</u>	<u>DESCRIPTION</u>
7356	8468 3	<p>Loading Sketch/Schematic/Design change</p> <p>1) Change L1 from 74367 (WL#376-0176) to 74368 (WL #376-0179)</p> <p style="text-align: center;"><u>REASON FOR CHANGE</u></p> <p>To make TC code universal.</p>
7357	0	None
7358	0	None
7359	7630 0	<p>Artwork/Schematic/Design Change</p> <p>1) Cut etch connecting connector J3 pin 24 (TST) to pin 15.</p> <p>NOTE: This change is needed to operate with certain modems (208B).</p> <p>2) Add wire jumper from I/O board connector 2 pin 19 (CR) to connector J2 pin 4.</p> <p>3) At connector J5, interchange pin 1 (18 VACT1) with pin 5 (+ OV) and interchange pin 2 (18VACT2) with pin 6 (+ OV).</p> <p><u>CAUTION:</u> This change was unintentional and creates an incompatibility with the previous (artwork revision R) motherboard. When changing motherboards, be sure that the two black transformer leads are connected to + OV and that the two yellow transformer leads are connected to 18VAC T1 and 18VACT2 respectively. If the transformer leads are not connected properly, then the unit's power line fuse (3A fast blow) will blow.</p> <p style="text-align: center;"><u>REASON FOR CHANGE</u></p> <p>Design corrections.</p>

**APPENDIX**  
**A**  
**DETAILED**  
**DESCRIPTION OF**  
**BISYNC**  
**COMMUNICATIONS**

APPENDIX A

DETAILED DESCRIPTION

OF

BISYNC COMMUNICATIONS

## A.1 INTRODUCTION

### A.1.1 SYNCHRONOUS TRANSMISSION

Synchronous is defined as happening at the same time or operating at exactly the same period and phase. This definition is directly applicable to synchronous transmission; the receiving station is synchronized to the transmitting station prior to data transmission. Before a block of data is sent, the oscillators in the data sets of both stations must be brought into phase. This is accomplished by the transmitting station sending a synchronization pattern at the start of the data block. If this synchronization process were not done, the receiving station would not be able to determine which bit received was the first character bit, thus making communication impossible. The sync pattern is followed by control characters, then data, which continues contiguously until a control character indicating the end of a block is encountered. At this time, the receiving station checks the next character or two characters (depending upon the type of block checking used) against a check character it has accumulated to determine if the block was transmitted correctly.

SYNC SYNC C DATA C E

Sync Pattern

Control Characters

Error Detecting Character(s)

FIGURE A-1 TYPICAL TRANSMISSION

## A.1.2 BINARY SYNCHRONOUS COMMUNICATIONS PROCEDURE

Binary Synchronous Communications (BSC) procedure provides a set of rules (established by IBM) for the synchronous transmission of binary coded data. BSC is able to accommodate a variety of transmission codes and supports a transparency feature that allows transmission of control characters and raw data within the message format without any control or graphic significance at the receiving terminal. This section describes BSC transmission codes, data link control and operations, error checking, message format, and some optional capabilities.

## A.1.3 THE DATA LINK

This consists of the communications lines, modems and any other communications equipment used in the transmission of information between two or more terminals. A terminal can be as simple as a single input device (for sending) and an output device (for receiving); or it could be made up of a control unit supporting several input and output devices. The terminal is interfaced to the communications lines through a modem. The modem can be obtained from communications common carriers or an equivalent may be provided by the customer. The specific modem used at each terminal is dependent upon the type of communications line and the operating speed of the terminal equipment. These components make up the hardware necessary for a data link. The type of data link is determined by terminal specifications. The specific type of data link we are concerned with is a point-to-point data link. Point-to-point means that there are only two terminals communicating to each other at a time. This type of a data link can be established over leased (nonswitched) lines or a switched network. Operation on leased lines are always between the same two terminals (a permanent connection) where on a switched network the data link is disconnected after the terminals complete their transmissions. A new data link can be established with any terminal in the network by using standard dialing procedures (Manual or Automatic).

#### A.1.4 TRANSMISSION CODES

BSC procedures are capable of handling three transmission code sets:

- 1) EBCDIC (Extended Binary Coded Decimal Interchange Code) - 256 assignment positions.
- 2) USASCII (United States of America Standard Code for Information Interchange) - 128 assignment positions.
- 3) Six-Bit Transcode - 64 assignment positions.

Each code set is comprised of data link control characters (e.g., SOH - Start of Heading, STX - Start of Text), endtoend control characters (e.g., EM - End of Media, HT - Horizontal Tab), and graphic characters (numeric, alphabetic, special). The choice of code set depends upon the application, however, to insure system compatibility, the same code should be used throughout the communications network. In addition to handling the above mentioned characters, BSC has another capability; a transparenttext mode. This transparent mode allows transmission of all possible bit configurations; assignment restrictions are removed from the code set being used. This means that within the standard message format any type of coded information can be handled using transparenttext mode.

#### A.2 OPERATION OF THE DATA LINK

The data link can be designed to operate either point-to-point (two terminals) or multipoint (several terminals). Since our system operates point-to-point, explanations of multipoint operation will not be included in this publication. A contention situation exists when using point-to-point operation, that is, both terminals can attempt to use the communications line simultaneously. To lessen the possibility of this occurring, a terminal bids for the line using the enquiry control character (ENQ). The enquiry sequence SYN SYN ENQ (where SYN SYN represent the sync characters sent before a



transmission) provides a concise method for requesting control of the line, therefore, leaving a maximum amount of time for line monitoring. In the event of two terminals bidding for a line simultaneously, one terminal must be equipped to persist in its bidding attempt to break the contention condition. Once a terminal gains control of the line, message transmission can begin.

#### A.2.1 MESSAGE BLOCKS

The message consists of one or more blocks of text data. The text is transmitted in blocks to provide more accurate and efficient error control. The text data is the body of the message and is identified by a start of text (STX) character immediately preceding each block of text. In addition, each block of text except the last is immediately followed by an end of transmission block (ETB) character or an intermediate block (ITB) character. The last block of text in a message is immediately followed by an end of text (ETX) character.

The text of the message can be preceded by a heading that contains auxiliary information (e.g., station control, priority, etc.) pertaining to the following text data. The heading is identified by a start of heading (SOH) character immediately preceding it.

For greater reliability, a unique character should always follow SOH to identify the heading function. The reason for this is to prohibit the possibility of heading data being interpreted as text data, or vice versa, due to transmission errors. This unique character should not be used following STX. The percent (%) character should not be used for this purpose, as SOH% is presently used to identify requestfortest or stationdependent control messages.

As each message block is completed, it is checked for transmission accuracy at the receiver before the transmission continues. (When VRC is used, each character is checked as it is received.)

## A.2.2 ERROR CHECKING

Each block of data transmitted is errorchecked at the receiving station in one of several ways, depending on the code and the functions employed. These checking methods are vertical redundancy checking (VRC), which is oddparity checking by character as the data is received, and either longitudinal redundancy checking (LRC) or cyclic redundancy checking (CRC), which check the block after it is received. After each transmission, the receiving station normally replies with ACK0 or ACK1 - data accepted, continue sending; or with NAK - data not accepted (e.g., a transmission error was detected), retransmit previous block. Retransmission of a block of data following an initial NAK is usually attempted at least three times. If the transmitting station receives no reply after sending a data block, or if the reply is garbled, the transmitting station can request a retransmission of the reply by sending an ENQ. When the transmitting station is through sending a message, it ends the transmission by sending an end of transmission (EOT) character. The specific BSC errorchecking capabilities available are shown, by code set, in Figure A-2.

TRANSMISSION CODE	NO TRANSPARENCY	TRANSPARENCY INSTALLED AND OPERATING	TRANSPARENCY INSTALLED BUT NOT OPERATING
EBCDIC	CRC	CRC	CRC
USASCII	VRC/LRC	CRC	VRC/CRC

FIGURE A-2 ERROR CHECKING CAPABILITIES

### A.2.2.1 VRC/LRC

VRC (vertical redundancy checking) is an oddparity check performed on a percharacter basis with the USASCII character set. It is not available with either the EBCDIC or SixBit Transcode character sets. The VRC oddparity check is performed on each character, including the LRC character.

LRC is a longitudinal redundancy check on the total data bits by message block. It is a basic form of CRC. An LRC character is accumulated at both the sending and receiving terminals during the transmission of a block. This accumulation is called the blockcheck character (BCC), and it is transmitted immediately following an ETB, ETX or ITB character. The transmitted BCC is compared with the accumulated BCC character at the receiving station for an equal condition. An equal comparison indicates a good transmission of the previous block.

The LRC accumulation is reset by the first STX or SOH character received after a line turnaround. All characters received thereafter, including control characters, until the next line turnaround, are included in the accumulation. Only SYN characters are not accumulated. Following an ITB BCC, the accumulation resets and starts again with the next received STX or SOH character.

#### A.2.2.2 CRC12/CRC16

Cyclic redundancy checking (CRC) is a more powerful method of block checking than LRC. Two modes of CRC are employed with BSC. The first, CRC12, is used for sixbit transmission codes; the second, CRC16, is used for eightbit transmission codes.

A cyclic redundancy check is a division performed by both the transmitting and receiving stations using the numeric binary value of the message as a dividend, which is divided by a constant. The quotient is discarded, and the remainder serves as the check character, which is then transmitted as the block check (BCC) character immediately following a checkpoint character (ITB, ETB, or ETX). The receiving station compares the transmitted remainder to its own computed remainder, and finds no error if they are equal.

The BCC accumulation consists of two bytes (e.g., 16 bits for CRC16) when it is transmitted on the line, but functionally is one sequence.

### A.2.2.3 EOT/NAK Pad Format Check

All BSC stations use the EOT/NAK pad format check to reduce the probability of a transmission line error converting an affirmative response (DLE sequence) into an EOT or NAK character. EOT and NAK must be followed by a trailing pad character of all "1" bits. Although all eight bits of the trailing pad character may be sent, the receiver should check only the first four bit positions. A station receiving an EOT or NAK within the text or heading of a transmission block (following STX or SOH) will treat the character as data and continue to receive or monitor the transmission (timeout, recognition of a turnaround character, etc.).

Similar pad format checking on DLE sequences and ENQ may be done on an optional basis.

### A.2.3 DATA-LINK CONTROL

Control of the data link is maintained through the use of these control characters and sequences:

- SYN - Synchronous Idle
- SOH - Start of Heading
- STX - Start of Text
- ITB - End of Intermediate Transmission Block
- ETB - End of Transmission Block
- ETX - End of Text
- EOT - End of Transmission
- ENQ - Enquiry
- ACK0/ACK1 - Alternating Affirmative Acknowledgements
- WACK - WaitBeforeTransmit Positive Acknowledgement
- NAK - Negative Acknowledgement
- DLE - DataLink Escape
- RVI - Reverse Interrupt
- TTD - Temporary Text Delay
- DLE EOT - Disconnect Sequence for a Switched Line

Several variations in the designations and compositions of the datalink control characters and sequences exist among the various code sets. For example, ACK0 and ACK1 are two character sequences having DLE as the first character. These and other variations are shown in Figure 33. Characters that remain the same in all code sets are designated by a dash (-).

#### A.2.3.1 SYN - Synchronous Idle

This character is used to establish and maintain synchronization and as a time fill in the absence of any data or other control character. Two contiguous SYN's at the start of each transmission (SYN SYN) are referred to as the characterphase sync pattern (represented by SYN in Figures and format examples).

#### A.2.3.2 SOH - Start of Heading

This character precedes a block of heading characters. A heading consists of auxiliary information (such as routing and priority) necessary for the system to process the text portion of the message.

#### A.2.3.3 STX - Start of Text

This character precedes a block of text characters. Text is that portion of a message treated as an entity to be transmitted through to the ultimate destination without change. STX also terminates a heading.

#### DATA LINK

CHARACTER	EBCDIC	USASCII	SIX-BIT TRANSCODE
SYN	-	-	-
SOH	-	-	-
STX	-	-	-
ETB	EOB(ETB)	-	-
ETX	-	-	-
EOT	-	-	-

ENQ	-	-	-
ACK 0	DLE '70'	DLE 0	DLE -
ACK 1	DLE 1	DLE 1	DLE T
NAK	-	-	-
DLE	-	-	-
ITB	IUS	US	US
WACK	DLE,	DLE;	DLE W
RVI	DLE @	DLE	DLE 2
TTD	STX ENQ	STX ENQ	STX ENQ

- indicates characters are the same in all code sets ' indicates the hexadecimal representation (no graphic assignment)

FIGURE A-3 CONTROL CHARACTER CONVERSION

#### A.2.3.4 ETB - End of Transmission Block

The ETB character indicates the end of a block of characters started with SOH or STX. The blocking structure is not necessarily related to the processing format. The blockcheck character is sent immediately following ETB. ETB requires a reply indicating the receiving station's status (ACK0, ADK1, NAK, or, optionally, WACK or RVI).

#### A.2.3.5 ITB - End of Intermediate Transmission Block

The ITB character (IUS in the EDCDIC charts and US in the USASCII and SixBit Transcode charts - interchange unit separator) is used to divide a message (heading or text) for error checking purposes without causing a reversal of transmission direction. The blockcheck character immediately follows ITB and resets the blockcheck count. After the first intermediate block, successive intermediate blocks need not be preceded by STX or SOH. (For transparent data, each successive intermediate block must begin with DLE STX.) If one intermediate block is heading and the next intermediate block is text, STX must begin the text block.

Normal line turnaround occurs after the last intermediate block, which is terminated by ETB or ETX (DLE ETB or DLE ETX for transparency). When one of these ending characters is received, the receiving station responds to the entire transmission. If a blockcheck error is detected for any of the intermediate blocks, a negative reply is sent, which requires retransmission of all intermediate blocks.

All BSC stations must have the ability to receive ITB and its attendant BCC. The ability to transmit the ITB character is a station option.

NOTE:

For some stations, ITB's in transparent data are permitted only at predetermined, fixed intervals within the transparent text. The receiver must be aware of the interval length.

A.2.3.6 ETX - End of Text

The ETX character terminates a block of characters started with STX or SOH and transmitted as a unit. The blockcheck character is sent immediately following ETX. ETX requires a reply indicating the receiving station's status.

A.2.3.7 EOT - End of Transmission

This character indicates the end of a message transmission, which may contain one or more blocks, including text and associated headings. It causes a reset of all stations on the line. EOT is also used as:

- 1) A response to a bid when that station has nothing to transmit.
- 2) An abort signal to indicate a system malfunction or operational situation that prohibits continuation of the message transmission.

#### A.2.3.8 ENQ - Enquiry

The ENQ character is used to obtain a repeat transmission of the response to a message block if the original response was garbled or was not received when expected. ENQ is also used to bid for the line when using a pointtopoint line connection.

#### A.2.3.9 ACK0/ACK1 - Affirmative Acknowledgement

These replies, in proper sequence, indicate that the previous block was accepted without error and the receiver is ready to accept the next block of the transmission. ACK0 is the positive response to a line bid (point-to-point).

#### A.2.3.10 WACK - Wait-Before-Transmit Positive Acknowledgement

WACK allows a receiving station to indicate a "temporarily not ready to receive" condition to the transmitting station. It can be sent as a response to a text or heading block, line bid (pointtopoint with contention) or an ID (identification) line bid sequence (switched network). WACK is a positive acknowledgement to the received data block or to selection.

The normal transmitting station response to WACK is ENQ, but EOT and DLE EOT are also valid responses. When ENQ is received, the receiving station will continue to respond with WACK until it is ready to continue. See the Continue Timeout discussion under Timeouts in the Message Formats for Basic Operation section for further explanation. An example of how WACK is used is shown below. The ability to receive WACK is mandatory for all BSC stations, but the capability to send WACK is optional.



EXAMPLES OF WACK USAGE

TRANS STATION:	SYN	TRANS STATION:	SYN
	ENQ		ENQ
RECV STATION:	SYN	RECV STATION:	SYN
	ACK 0		ACK 0
TRANS STATION:	SYN	TRANS STATION:	SYN
	STX		STX
	X		X
	X		X
	ETB		ETB
	BCC		BCC
RECV STATION:	SYN	RECV STATION:	SYN
	WACK		WACK
TRANS STATION:	SYN	TRANS STATION:	SYN
	ENQ		ENQ
RECV STATION:	SYN	RECV STATION:	SYN
	ACK 1		WACK
TRANS STATION:	SYN	TRANS STATION:	SYN
	STX		EOT
	X	OR	
	X		o
	ETX		DLE
	BCC		EOT

NOTE:

SYN = Sync Characters

XX = Text

A.2.3.11 NAK - Negative Acknowledgement

NAK indicates that the previous block was received in error and the receiver is ready to accept a retransmission of the erroneous block. It is also the "not ready" reply to station selection or line bid.

#### A.2.3.12 DLE - DataLink Escape

DLE is a control character used exclusively to provide supplementary line control characters, such as WACK, ACKO, ACK1, RVI, and transparent mode control characters. The sequences DLE STX, DLE ETX, DLE ITB, and DLE ETB initiate and terminate transparent text. In addition, other DLE control sequences (DLE ENQ, DLE DLE, DLE EOT) are used to provide active control characters within transparent text as required. For additional information, see the TransparentText Mode discussion in the Additional Data Link Capabilities section.

#### A.2.3.13 RVI - Reverse Interrupt

The RVI control sequence is a positive response used in place of the ACKO or ACK1 positive acknowledgement. RVI is transmitted by a receiving station to request termination of the current transmission because of a high priority message which it must transmit to the sending station. Successive RVI's cannot be transmitted, except in response to ENQ.

The sending station treats the RVI as a positive acknowledgement, and responds by transmitting all data that prevents it from becoming a receiving station. More than one block transmission may be required to empty the sending station's buffers.

The character structure of the RVI control sequence is as follows:

	EBCDIC
DLE@	
	USASCII
DLE	
	SixBit Transcode
DLE2	

The ability to receive RVI is mandatory for all BSC stations, but the ability to transmit RVI is optional. The example below illustrates the use of RVI.

#### RVI USAGE

TRANS STATION:	SYN	ENQ	
RECV STATION:	SYN	ACK 0	
TRANS STATION:	SYN	STX	
	X		
	X		
	ETB		
	BCC		
RECV STATION:	SYN		RVI
TRANS STATION:	SYN		STX
	X		
	X	Empty I/O Buffer	
	ETB	ETX if last block of message	
	BCC		
RECV STATION:	SYN		ACK 0
TRANS STATION:	SYN		EOT

#### A.2.3.14 TTD - Temporary Text Delay

The TTD control sequence is sent by a sending station in message transfer state when it wishes to retain the line but is not ready to transmit. The TTD control sequence (STX ENQ) is normally sent after approximately two seconds if the sending station is not capable of transmitting the next text block or initial text block within that line. This two second timeout avoids the nominal three second receive timeout at the receiving station (see example below).

The receiving station responds NAK to the TTD sequence, and waits for transmission to begin. If the sending station is still not ready to transmit, the TTD sequence can be repeated one or more times.

This delay in transmission can occur when the sending station's input device has not completely filled the buffer due to inherent machine timings. TTD is also transmitted by a sending station in message transfer mode to indicate to the receiver that it is aborting the current transmission (see example below). After receiving NAK to this TTD sequence, the sending station sends EOT, resetting the stations to control mode (forward abort).

#### TTD USAGE

```

TRANS STATION:  SYN
                 ENQ
RECV STATION:   SYN
                 ACK 0  _ _ _
                               Less than or equals 2 seconds.
                 _ _ _
TRANS STATION:  SYN
                 STX  TTD
                 ENQ
RECV STATION:   SYN
                 NAK  _ _ _
                   F
                 STX  TTD
                 ENQ
RECV STATION:   SYN
                 NAK
TRANS STATION:  SYN
                 STX
                   X
                   X
                 ETX
                 BCC
RECV STATION:   SYN
                 ACK 1

```

## FORWARD ABORT SEQUENCE

TRANS STATION: SYN  
ENQ  
RECV STATION: SYN  
ACK 0  
TRANS STATION: SYN  
STX  
X  
X  
ETB  
BCC  
RECV STATION: SYN  
ACK 1  
TRANS STATION: SYN  
STX  
ENQ  
RECV STATION: SYN  
NAK  
TRANS STATION: SYN  
EOT

### A.2.3.15 DLE EOT - Disconnect Sequence for a Switched Line

Transmission of DLE EOT on a switched line indicates to the receiver that the transmitter is going "on-hook". Either the calling or the called station may transmit this disconnect sequence. DLE EOT is normally transmitted when all message exchanges are complete, and may optionally be transmitted at any time instead of EOT to cause a disconnect.

### Alternating Affirmative Acknowledgements

The BSC procedures specify the alternate use of ACK0 and ACK1 as affirmative replies. The use of ACK0 and ACK1 provides a sequential checking control for a series of replies. Thus it is possible to maintain a running check to ensure that each reply corresponds to the immediately preceding message block. ACK0 is always used as the affirmative reply to selection or line bid.



If block checking is desired for the heading alone, the heading can be ended with ETB. This is followed by the BCC and appears as shown in Figure A-5.

```
          S           E B
SYN O  Heading T C
          H           B C
```

FIGURE A-5 BCC ACCUMULATION - HEADING ONLY

The heading can be terminated prematurely by use of the ENQ (indicating "disregard this block"). The use of this character is shown in Figure A-6.

```
          S           E
SYN O  Heading N
          H           Q
```

FIGURE A-6 ENQ USED TO TERMINATE A HEADING

NOTE:

A negative reply is required from the receiving station, since the heading ended with a forced error condition. Transmission should continue following this sequence and will normally be a retransmission of the same block.

### A.3.2 TEXT

The text data is the most significant portion of the transmission. It is transmitted in complete units called messages, which are initiated by STX and concluded with ETX. Each message is a complete unit that can stand alone and is not necessarily directly related to other messages being transmitted. A message can be subdivided into smaller blocks for ease in processing and more efficient error control. Each block starts with STX and ends with ETB (except for the last block of a message, which ends with ETX). A single transmission can contain any number of blocks (ending with

ETB) or messages (ending with ETX). An EOT following the last ETX block indicates a normal end of transmission. Message blocking without line turnaround can be accomplished by using ITB (see the Additional Data Link Capabilities section).

Control characters or sequences within a block of text are not allowed. Any station receiving a control character within a text block treats the control character or sequence as data and waits for the block check character (BCC) to detect a possible error. If an error is detected, normal recovery procedures are used. If no error is detected, the transmission is treated as valid data.

The following figures are examples of various forms of block transmission for text data. Figure 37 shows the last text block of a message, and Figure 38 shows the format for other text blocks.

```
TRANS STATION:  SYN
                 STX
                 X
                 X
                 ETX
                 BCC
RECV STATION:   SYN
                 ACK 1/0
TRANS STATION:  SYN
                 .
                 .   Next message, SOH, STX, or EOT
                 .
```

FIGURE 3-7 FORMAT OF LAST TEXT BLOCK

```
TRANS STATION:  SYN
                 STX
                 X
                 X
                 ETB
                 BCC
```



```

RECV STATION:  SYN
                ACK 1/0
TRANS STATION:  SYN
                STX
                .
                .   Next message
                .

```

FIGURE A-8 FORMAT OF A NORMAL TEXT BLOCK

A block of text data can be terminated prematurely by using an ENQ character, which signals the receiver to "disregard this block". NAK is always the reply in this situation, since the block ended with a forced error condition. An example is shown in Figure A-9.

```

TRANS STATION:  SYN
                STX
                X
                X
                ENQ
RECV STATION:   SYN
                NAK
TRANS STATION:  SYN
                STX
                .
                .   Normally a retransmission of the block in
                .   error
                .

```

FIGURE A-9 FORMAT OF BLOCK ENDED WITH FORCED ERROR CONDITION

### A.3.3 POINT-TO-POINT OPERATION (WITH CONTENTION)

This type of operation is available for either privately owned lines or leased private lines. When transmission is started, an initialization sequence (consisting of 0

by the station attempting to acquire the line. A station receiving this sequence (and ready for message reception) replies with 0

    SYN NAK (Negative Acknowledge)

    SYN WACK (Wait Before Transmit Positive Acknowledge).

The format for the complete initialization phase, including the start of the actual message transmission, is shown in Figure A-10.

```
TRANS STATION:  SYN
                 ENQ      Initialization Phase
RECV STATION:   SYN
                 ACK 0
TRANS STATION:  SYN
                 STX
                 X
                 X
                 ETB
                 BCC
RECV STATION:   SYN
                 ACK 1
TRANS STATION:  SYN
```

FIGURE A-10 COMPLETE INITIALIZATION PHASE

To avoid the problems associated with simultaneous transmission requests, each station is assigned a priority - primary or secondary. The higher priority (primary) station sends an ENQ to acquire the idle line; it will continue to do so until it receives an affirmative response or until the retry limits of the primary station are reached. If the primary station receives an ENQ and it has not initiated a request for the line, then it replies with ACK 0 (if ready to receive), WACK or NAK. Thus the secondary station can gain control of the line for a transmission only when the line is left free by the primary station.

Message transmission is ended and the line is returned to an idle state by the transmission of EOT. The station sending EOT will not send an initialization sequence before three seconds have elapsed, thus allowing the other station to bid for the line.

#### A.3.4 ADDITIONAL FORMAT CONSIDERATIONS

The sync pattern and pad character are an integral part of block and controlsequence formats in BSC operation. The sync pattern ensures that all active stations in the data link operate in step. The pad character ensures full transmission and reception of the first and last significant character of each transmission. Neither pad nor sync characters are reflected in the received message; however, both must be properly provided for in the original message format before transmission.

##### A.3.4.1 Sync Patterns

Transmission over the data link is serialbybit, serialbycharacter, with synchronization of the transmitted data established by transmission of an appropriate sync pattern. This pattern must be sent at the start of each transmission to ensure that the receiving stations are in step with the sending station. Synchronization of all transmitted data is established at bit and character level through use of this sync pattern. Each bit received must be in the proper time relationship so that it can be correctly identified (sampled). Also, each series of bits must be assembled in the correct relationship to ensure assembly of the proper bits to create the originally transmitted character.

The sync pattern always precedes a transmission and is used to establish bit and character synchronization between transmitter and receiver.

## Character Phase

The synchronizing pattern for establishing character phase consists of at least two contiguous SYN characters. If more than two are sent, the sync pattern ends with the last transmitted SYN.

Character phase must be reestablished for each transmission. This is accomplished by the receiving station recognizing at least two contiguous SYN characters in the bit stream. Character phase remains established at the receiving station until either (1) a line turnaround character or the endoftransmission character is received, or (2) a timeout is complete.

## Pad Characters

To ensure that the first and last characters of a transmission are properly transmitted by the data set, all BSC stations add a pad character before and after each transmission. The onecharacter pad (leading pad) preceding each initial synchronizing pattern ensures that the station will not start sending its synchronizing pattern before the other station is prepared to receive. The leading pad character may consist of alternating "0" and "1" bits (hex "55") or a SYN character.

A pad character (trailing pad) is also added following each transmission (e.g., NAK, EOT, ENQ). Since ETB or ETX causes line turnaround, the pad character follows the BCC. The trailing pad character ensures that the last significant character (e.g., ETB BCC, ETX BCC, or NAK) is sent before the data set transmitter turns off. The trailing pad character consists of all "1" bits (hex "FF").

### A.3.4.2 Timeouts

Timeouts are used to prevent indefinite data link tieups, due to false sequences or missed turnaround signals, by providing a fixed time within which any particular operation must occur. Due to the different requirements for the various operations, four specific timeout functions are provided: transmit, receive, disconnect, and continue.

## Transmit Timeout

This is a nominal one second timeout that establishes the rate at which sync idles are automatically inserted into transmitted heading and text data. In normal data, two consecutive sync-idle characters (SYN SYN) are inserted every second, while for transparent data, one transparent syncidle sequence (DLE SYN) is inserted every second. If business machine clocking is used, DLE SYN insertion is required at least every 84 characters to insure maintenance of bit synchronization in the event of transitionless data. There must be at least 54 characters between each DLE SYN. Sync idles are inserted in the message for timing purposes only, and have no effect on the message format. If SYN characters are transmitted for a period of greater than 3 seconds, the Write command will timeout.

## Receive Timeout

This is a nominal three second timeout, and is used as follows:

- (a) Limits the waiting time tolerated for a transmitting station to receive a reply.
- (b) Permits any receiving or monitoring station to check the line for syncidle signals. These sync idles indicate that the transmission is continuing; thus, this timeout is reset and restarted each time a sync idle is detected.
- (c) Limits the time any tributary station in a multipoint network will remain in control mode while monitoring the line for its address code. This timeout runs whenever the station is in control mode. It is reset and restarted each time an end signal (EOT, ENQ, NAK, WACK, ACK) is recognized, as long as the station remains in control mode.

## Disconnect Timeout

This timeout is used optionally on switched network data links. It is a nominal 20 second timeout used to prevent a station holding a connection for prolonged periods of inactivity. After 20 seconds of inactivity, the station will disconnect from the switched network.

## Continue Timeout

This is a nominal two second timeout associated with the transmission of TTD and WACK. The continue timeout is used by stations where the speed of input devices (for transmitting stations) or output devices (for receiving stations) affect buffer availability and may cause transmission delays.

TTD is sent by the transmitting station up to two seconds after receiving acknowledgement of the previous block if the transmitting station is not capable of sending the next transmission block before that time.

A receiving station must transmit WACK to indicate a "temporarily not ready to receive" condition if it is not able to receive within the two second timeout. The purpose of the timeout intervals is to permit the receiving station to send an appropriate affirmative reply immediately if it becomes appropriate within the interval.

#### A.4.4 I/O AND BUFFER CHECK

An I/O or buffer check condition at the transmitting terminal will cause transmission to end. This is accomplished by transmitting an ENQ in text. The receiving terminal responds with a NAK, and after the transmitting terminal receives the NAK, it sends an EOT.

With a line-buffer parity check or linebuffer overflow, the ENQ is transmitted immediately upon detection of the check. With an I/O or I/O buffer check condition, those complete records in the line buffer will be transmitted normally. Following a correct response to the block check, an STX ENQ sequence is sent by the transmitting terminal. This sequence is the same as an ENQ in text and the resultant sequence is identical.

Example: Line-Buffer Parity or Overflow

```
TRANS STATION:  SYN
                 STX
                 TEXT
                 ENQ
RECV STATION:   SYN
                 NAK
TRANS STATION:  SYN
                 EOT
```

Example: I/O or I/O Buffer Check

```
TRANS STATION:  SYN
                 STX
                 TEXT
                 ETB
                 bcc
                 bcc
RECV STATION:   SYN
                 ACK 1
TRANS STATION:  SYN
                 STX
                 ENQ
```

RECV STATION: SYN  
NAK  
TRANS STATION: SYN  
EOT

A line-buffer overflow at a receiving terminal results in a NAK response to a block-checking sequence. All other buffer and I/O check conditions result in an EOT response to the block-checking sequence.

Example: Receiving Terminal Buffer or I/O Check

RECV STATION: SYN  
STX  
TEXT  
ETB  
bcc  
bcc  
TRANS STATION: SYN  
EOT

## A.5 TIMEOUT CONTROLS

Two or more terminals, in a ready to transmit condition and using the same communications line, can bid for the line simultaneously. When this contention-for-the-line condition occurs, neither terminal recognizes the request of the other(s). Therefore, timeout controls are provided by the basic 2780 terminal. These timeout controls are used to establish priority when a contention-for-the-line condition exists, thereby preventing the transmission line from being tied up unnecessarily under certain adverse conditions.

### A.5.1 ONE-SECOND TIMEOUT

This timeout is used when operating point-to-point on a contention basis. It is the period of time that a primary terminal allows a secondary terminal to reply to the Enquiry (ENQ) character. The primary terminal automatically retransmits the ENQ character after the onesecond timeout.



#### A.5.2 TWO-SECOND TIMEOUT

A receiving terminal must respond to a block-checking operation within two seconds. If unable to do so, the receiving terminal remains in receive mode and waits for the transmitting terminal to send an ENQ character to solicit the response.

#### A.5.3 THREE-SECOND TIMEOUT

This timeout is used when operating point-to-point on a contention basis. It is the period of time that a secondary terminal allows a primary terminal to reply to an ENQ character. At the end of this timeout the ENQ character is automatically encoded again and sent to the primary terminal.

A transmitting terminal will wait three seconds for a response to a block-checking operation. If a reply is not received, an ENQ is automatically encoded and sent to the receiving terminal to solicit the response.

A receiving terminal initiates a threesecond timeout upon receiving a sync pattern (SYN SYN). It must receive an STX character or another sync pattern within this time. If none is received, the terminal abandons synchronization and waits for another sync pattern. Upon receiving an STX character, another three-second timeout is initiated. If a blockend character or a sync pattern is not received within this time, synchronization is abandoned.

When operating terminal-to-terminal over leased lines, one terminal must be designated the primary terminal and the other the secondary terminal. This enables the primary terminal to gain control of the line if both terminals bid for the line simultaneously. This designation is not necessary when operating terminal-to-terminal over switched (dial) line facilities, since the operators control the priority of the terminals. In a terminal-to-CPU (contention mode) operation, the 2780 is always the primary terminal. The CPU will wait for the 2780 to send the second ENQ character if the CPU receives an ENQ response to its ENQ character.

This condition could exist if both the 2780 and the CPU send ENQ characters at approximately the same time.

If, in a terminal-to-CPU operation, the CPU transmits for longer than one second without a turnaround, the CPU must send sync patterns at one second intervals.

#### A.5.4 EXTENDED ENQ RETRY FEATURE (48-SECOND TIMEOUT)

The Extended Enquiry (ENQ) Retry Transmission feature is required only when 2780 terminals are used with a System/360 that is processing data transmitted over many communications lines. Under these circumstances the CPU may experience difficulty in responding to a specific 2780 communications line within the present 12second timeout limitation. The availability of this feature is standard for Wang 2780 terminal using EBCDIC code.

#### A.5.5 STANDARD 2780 OPERATION

A block check response other than ACK 0, ACK 1, NAK, EOT, or RVI causes the transmitting 2780 to send an ENQ (Enquiry) character. The ENQ character is also transmitted if the transmitting 2780 receives no response at all within three seconds. The ENQ character serves as a request to the receiving CPU to repeat the last block check response. A maximum of three retry ENQ characters are transmitted by a standard 2780 terminal. Failure to receive a recognized response after three ENQ's causes the transmitting 2780 to send an EOT character and time out. The EOT character is transmitted three seconds after the last ENQ is transmitted.

#### A.5.6 2780 OPERATION WITH EXTENDED ENQUIRY RETRY TRANSMISSION FEATURE INSTALLED

The purpose of the Extended Enquiry (ENQ) Retry Transmission feature is to allow the transmitting 2780 to count up to a maximum of 15 retry ENQ's in an effort to recognize a response prior to sending an EOT character and timing-out with an error condition.

Since three seconds elapse between each retry, and also between the last ENQ and EOT character, a total of forty eight seconds elapse before an EOT character is transmitted ending the transmission.

NOTE:

The Wang 2780 Terminal always uses Extended Enquiry Retry transmission feature. 4.6 WANG 2780 SPECIAL FEATURES

A.6.1 MULTIPLE RECORD TRANSMISSION

This special feature allows up to seven records to be transmitted before a line turnaround occurs. However, if the 2780 is operating at 4800 bps line speed, no additional throughput can be expected when this feature is used. The specific number of records depends upon the length of each record (with a maximum total of 400 characters). If less than 80 characters are to be read, the record length is defined by use of the EM (End of Media) character. The US, ETB, or ETX control character will be transmitted following the transmission of the EM character. Full 80-character records will generate a US, ETB or ETX control character automatically.

The 400-character limitation includes all data; all component selection, vertical forms control, and horizontal forms control sequences; and all end of record characters but it does not include the STX character that the 2780 encodes when transmitting. When the EBCDIC code is used, the transmitting and receiving terminal will consider the modified LRC check characters as part of the 400character limitation. One modified LRC check character is generated for each record.

Line buffer overrun will not occur until more than seven records per block are received or the 400-character limitation is exceeded, when this feature is installed.

## A.6.2 EBCDIC TRANSPARENCY

The Transparency feature allows all possible bit combinations in the EBCDIC code to be used as data. Therefore, all 256 card codes can be punched and read by the Wang 2780. A control character is treated as data unless it is preceded by the DLE character. A DLE character to be treated as data must be followed by another DLE character. The extra DLE character is automatically inserted by the transmitting terminal and does not have to be punched in the input media. One of the DLE characters is discarded by the receiving terminal.

Transparent-text-mode operation is initiated by a machine generated DLE STX sequence, and terminated by a DLE character that is followed by a record or a block character (US, ETB, or ETX). In transparent operation, two SYN characters must be transmitted following transmission of a US record-check sequence. After the US record character, transparent text mode is re-established by another machinegenerated DLE STX sequence. A change from transparent text to normal text, or from normal text to transparent text, can occur only after a block-checking sequence (ETB, ETX). The line format is as follows:

S S S D S		D <sub>U</sub> b b S S D S		D E b b p
Y Y Y L T	Text	L <sub>S</sub> c c Y Y L T	Text	L T c c a Turnaround
N N N E X		E c c N N E X		E B c c d

The DLE characters are inserted when the characters are transferred to the line from the line buffer, and are deleted at the receiving terminal before entering the line buffer by the Binary Synchronous Adapter. The SYN characters following the US sequence are required to maintain bit synchronism and character phase between records of text.

All transmitted records are 80 characters long that is, an EM or ETX character read from the card will not cause reading to stop.

The first column 80 read causes a US sequence to be encoded; the second column 80 read causes an ETB sequence to be encoded. With the end-of-file switch on, a DLE ETX will be encoded when the last card is read. Transmission of ETX as a messageend character can be caused only by the end-of-file function since an ETX read from the card will be treated as data.

The following conditions must be adhered to when operating in the transparent mode:

- 1) When a punch is receiving text in transparent mode, the length of the record must be 80 characters.
- 2) Data records transmitted to a printer in a terminal-to-terminal system are 80 characters in length. When operating in a transparent mode and the printer is selected; a vertical forms control sequence (as the first two characters of a record) initiates a carriage function as in normal mode.
- 3) Data records transmitted to a printer in a CPU-to-terminal operation must be equal to the print-span requirement.
- 4) Records with vertical-forms-control sequences must be 82, 122, or 146 characters long to provide a record length of 80, 120, or 144 characters.
- 5) Component selection and Printer Horizontal Format Control will not operate with transparent text.
- 6) Component selection (punch or printer) must be executed while operating in normal mode; however, once the selection has been made it remains in effect for all subsequent transparent blocks of text until another selection is made in normal mode or until an EOT is transmitted.
- 7) The Multiple-Record special feature is operative in transparent mode; however, the records must be of fixed length as previously described.

## A.7 DATA LINK CONTROL FORMAT

The Wang 2780 Emulator basic line control allows the terminal to operate on a point-to-point system with another 2780 or a CPU.

### A.7.1 SERIALIZER SYNCHRONIZATION

Each transmission begins with a sync pattern of three consecutive SYN characters. To obtain synchronization (or character phase), a receiving terminal must receive at least two consecutive SYN characters. A terminal, ready to transmit, must first determine that the remote unit is able to receive. This request to transmit is made by the transmission of an ENQ. On receipt of the ENQ, a remote unit will respond with ACK 0 if it is ready to receive data, or with NAK if it is not ready to receive data.

Example: Simple Point-To-Point Operation

```
TRANS STATION:  SYN
                  ENQ
RECV STATION:   SYN
                  ACK 0
TRANS STATION:  SYN
                  STX
                  TEXT A (Odd)
                  ETB
RECV STATION:   SYN
                  ACK 1
TRANS STATION:  SYN
                  STX
                  TEXT B (Even)
                  ETX
RECV STATION:   SYN
                  ACK 0
TRANS STATION:  SYN
                  EOT
```

Any response other than ACK 0 or NAK to a request to transmit will result in a retransmission of the ENQ.

If a negative reply to an ENQ occurs, the ENQ will be repeated until a positive reply occurs, or until three inquiries have been sent. If the reply to the third ENQ is still negative, an EOT is sent. In a point-to-point configuration, one terminal can be designated the primary terminal and the other the secondary terminal. In a terminal-to-CPU operation, the terminal is always the primary terminal. A primary terminal is the terminal that will transmit data first if both stations try to initiate transmission at the same time. A primary terminal will wait one second for a response to its ENQ before retransmitting the ENQ.

A secondary station will wait three seconds for a response to its ENQ before sending ENQ again. If the secondary station receives an ENQ as a response to its ENQ, it will respond as if it had never tried to initiate transmission i.e., with ACK 0 or NAK, depending on its readiness to receive. However, it will initiate the request for transmission of its data after it receives an EOT from the primary terminal. If both stations send ENQ at the same time, neither will respond to the other's bid. The primary station will then gain control of the line with a second ENQ before the secondary's second ENQ. ACK 0 is always the positive reply to a line-bid ENQ. There is no alternation as in the checking procedure. NAK is the negative reply.

After an EOT appears on the line, both terminals go into control mode. Any ENQ in control mode is interpreted as a line bid. Both stations go into text mode with the appearance of an STX on the line. Text mode is maintained until an EOT appears again. In text mode, an ENQ is interpreted as a request for a response to checking.

Example: Point-to-Point Line Control Sequence

	E		E S		E F A		A
PRIMARY	N (1 sec)	N T	Text	T O	CO		Cl
	Q	Q X		X T	K		K
			(Odd)				
	E	A		A E S		F E	
SECONDARY	N	CO		Cl N T	Text	T O	
	Q	K		K Q X		X T	
					(Odd)		

A.7.2 FORMAT, RESPONDING TO TRANSMISSION OF TEXT

Positive Response

TRANS STATION:	SYN
	STX
	TEXT
	ETB
	bcc
	bcc
RECV STATION:	SYN
	ACK 0 or ACK 1
TRANS STATION:	SYN
	STX
	TEXT

Negative Response

TRANS STATION:	SYN
	STX
	TEXT A
	ETB
	bcc
	bcc



RECV STATION: SYN  
NAK  
TRANS STATION: SYN  
STX  
TEXT A (Retransmission)

Invalid or No Response

TRANS STATION: SYN  
STX  
TEXT  
ETB  
bcc  
bcc  
RECV STATION: NO RESPONSE  
TRANS STATION: SYN  
ENQ  
RECV STATION: NO RESPONSE  
TRANS STATION: SYN  
ENQ  
RECV STATION: NO RESPONSE  
TRANS STATION: SYN  
ENQ  
RECV STATION: NO RESPONSE  
TRANS STATION: SYN  
EOT

### A.7.3 FORMAT, EOT RESPONSE OR INCOMPLETE TRANSMISSION

EOT Response

TRANS STATION: SYN  
STX  
TEXT  
ETB  
bcc  
bcc

RECV STATION: SYN  
EOT  
TRANS STATION: (Re-establish communication)

Incomplete Transmission

TRANS STATION: SYN  
STX  
TEXT  
ENQ  
RECV STATION: SYN  
NAK  
TRANS STATION: SYN  
EOT (Re-establish communication)

4.7.4 FORMAT, ERROR CONDITIONS

Line Failure

TRANS STATION: SYN  
ENQ  
RECV STATION: SYN  
ACK 0  
TRANS STATION: SYN  
STX  
TEXT A (Odd)  
ETB  
bcc  
bcc  
RECV STATION: SYN  
ACK 0 (Line failure during  
TRANS STATION: SYN response; character 1  
ENQ changed to 0)  
RECV STATION: 0  
ACK 1  
TRANS STATION: 0  
STX  
TEXT

Out of Step

TRANS STATION: SYN  
ENQ  
RECV STATION: SYN  
ACK 0  
TRANS STATION: SYN  
STX  
EXT A (Odd)  
ETB  
bcc  
bcc  
RECV STATION: SYN  
ACK 1  
TRANS STATION: SYN  
STX  
TEXT B (Even)  
ETB  
bcc  
bcc  
RECV STATION: SYN  
ACK 1 (Response should have  
TRANS STATION: SYN been ACK 0  
ENQ  
RECV STATION: SYN  
ACK 1  
TRANS STATION: SYN  
ENQ  
RECV STATION: SYN  
ACK 1  
TRANS STATION: SYN  
ENQ  
RECV STATION: SYN  
ACK 1  
TRANS STATION: SYN  
EOT

## A.7.5 FORMAT, RETRANSMISSION

### Negative Response

```
TRANS STATION:  SYN
                 ENQ
RECV STATION:   SYN
                 ACK 0
TRANS STATION:  SYN
                 STX
                 TEXT A
                 ETB
                 bcc
                 bcc
RECV STATION:   SYN
                 NAK
TRANS STATION:  SYN
                 STX
                 TEXT A
                 ETB
                 bcc
                 bcc
RECV STATION:   SYN
                 ACK 1
TRANS STATION:  SYN
                 STX
                 TEXT B
```

Text will be retransmitted three times before stop condition when operating terminal-to-terminal.

### No Response

```
TRANS STATION:  SYN
                 ENQ
RECV STATION:   SYN
                 ACK 0
```

TRANS STATION: SYN  
STX  
TEXT  
ETB  
bcc  
bcc  
RECV STATION: NO RESPONSE  
TRANS STATION: TIME OUT  
TRANS STATION: SYN  
ENQ  
RECV STATION: NO RESPONSE  
TRANS STATION: SYN  
TIME OUT  
TRANS STATION: SYN  
ENQ  
RECV STATION: NO RESPONSE  
TRANS STATION: TIME OUT  
TRANS STATION: SYN  
ENQ  
RECV STATION: NO RESPONSE  
TRANS STATION: TIME OUT  
TRANS STATION: SYN  
EOT

STX Missed (Out-of-Step Condition)

TRANS STATION: SYN  
ENQ  
RECV STATION: SYN  
ACK 0  
TRANS STATION: TEXT A  
ETB  
bcc  
bcc  
RECV STATION: NO RESPONSE

TRANS STATION: TIME OUT  
                  SYN  
                  ENQ  
RECV STATION:    SYN  
                  ACK 0  
TRANS STATION:  SYN  
                  STX  
                  TEXT A  
                  ETB  
                  bcc  
                  bcc  
RECV STATION:   SYN  
                  ACK 1  
TRANS STATION:  SYN  
                  STX  
                  TEXT B

#### A.8 SUMMARY OF RESPONSES TO ERRORS

The following describes the various error conditions possible during a transmit or receive operation along with the line responses.

##### A.8.1 NAK

Four error conditions cause the receiving terminal to respond with a NAK:

- 1) An incorrect CRC or VRC/LRC check.
- 2) A response to an ENQ after detecting an EOT in text.
- 3) Receipt of a block with too many records, or overrun of the line buffer.
- 4) Transmission not completed (no US, ETB, or ETX received).

### A.8.2 EOT

An EOT response to a block of data is sent if any of the following check conditions occur at the receiving terminal:

- Hopper-Feed failure or empty.
- Punch Station-Misfeed or jam.
- Read Station-Misfeed or jam.
- Transport-Jam in stacker transport.
- Feed Clutch-Extra feed cycle.
- Equipment Check Incorrect punch or invalid punch combinations.
- Overrun-Record exceeding 170 characters.
- Buffer Parity Error-Both line and I/O buffer.
- Sync Check-Type bar out of synchronization.
- Forms Check-Jam, interlocks not made, etc.
- End-of-Forms Check-End of forms and channel 1 sensed.
- Component-Selection Error-Selection of not ready component when only one component ready.
- Miscellaneous Loss of Printer or Punch Ready Punch or printer stop key pressed, stacker full, or chip box full or not in position.

### A.8.3 STX, ENQ

When any of the following checks occur at the transmitting terminal, the good records in the line buffer at that time are transmitted as a block (ETB inserted after last record):

- Hopper Check-Failure to feed.
- Punch Station-Misfeed or jam.
- Read Station-Misfeed, jam, or defective photo transistor.
- Transport-Stacker-transport jam.
- Feed Clutch-Extra feed cycle.
- Data Check-Cards off registration; invalid combination of punches in cards; or US, ETX, EOT, NAK, or ENQ character read from card.
- Equipment Check-Failure to read all 80 columns with no EM or ETX.

Overrun-I/O buffer overrun.

Buffer Parity Check-In I/O buffer.

Miscellaneous Loss of Reader Ready-Stacker full, hopper empty,  
stop key pressed, or chip box full or not in position.

After receiving a positive response to the good records in the line buffer that were transmitted as a block, the transmitting terminal encodes the STS, ENQ characters.

#### A.8.4 ENQ

When transmitting, the 2780 encodes the ENQ character at the time the error occurs for the following conditions:

Buffer Parity Check-Line buffer for all codes.

Buffer Overrun-Line buffer.



**APPENDIX**

**B**

**BILL**

**OF**

**MATER-**

**IALS**

APPENDIX B

BINARY SYNCHRONOUS  
COMMUNICATIONS OPTION  
BILL OF MATERIALS

ASSEMBLY PART NUMBER 209-7354- - -  
 ASSEMBLY DESCRIPTION PCB ASSY 928 TCP MEMORY

LEGEND  
 1: P=PHANTOM; 2: ITFM MASTER DELY CODE; 3: \*=TAGGED OUT (OF KIT(PROD STR)

PCSTION IN STRUCTURE	LEGEND			COMPONENT PART NUMBER	DESCRIPTION	E C N	QUANTITY PFR ASSY	U/M	IML
	1	2	3						
1		IN		000-0001-	LABOR SUB-SYSTEMS		1.9570		
1		IN		000-0011-	LABOR QUALITY CONTROL		.3910		
1		IN		300-1900-	CAP .05 UF +80-20% 12 V CERAMIC D	PATREL	11.0000	EACH	
1		IN		300-1930-	.1 UF 50V +80-20% CERAMIC CAP(HIFREQ)	EC7611	20.0000	EACH	
1		IN		300-1931-	1 UF CERAMIC CAPACITOR(HIGH FREQ)		18.0000	EACH	
1		IN		300-4017-	CAP 5.6 UF 35 V 10% TANT AXIAL	PATREL	4.0000	EACH	
1		IN		300-4018-	CAP 18.0 UF 15 V 10% TANT AXIAL	PATREL	2.0000	EACH	
1		IN		300-4022-	CAP 15.0 UF 20 V 10% TANT AXIAL	PATREL	3.0000	EACH	
1	2	P FS *		330-1011-4R-	RES 10 OHM 1/4W 5% FIXED COMP		4.0000	EACH	
1	2	FS *		330-1011-	RES 10 OHM 1/4W 5% FIXED COMP		1.0000	EACH	
1		P FS *		330-3022-4R-	RES 2.2K OHM 1/4W 10% FIXED COMP		11.0000	EACH	
1	2	FS *		330-3022-	RES 2.2K OHM 1/4W 10% FIXED COMP		1.0000	EACH	
1		IN		375-1050-	TRANSISTOR SPS6551		4.0000	EACH	
1		IN		376-0002-	IC 7400N 4 2 IN POS NAND GATE		1.0000	EACH	
1		IN		376-0010-	IC 7404N HEX INVERTER		1.0000	EACH	
1		IN		376-0011-	IC 7493N 4 BIT BINAPY COUNTER		2.0000	EACH	
1		IN		376-0049-	IC 74155 2 2-4 LINE DECODER DMX	EC7307	1.0000	EACH	
1		IN		376-0093-	IC 7432 4 2 IN OR GATE		1.0000	EACH	
1		IN		376-0175-	IC 8T26 3 STATE 4 BUS TRANSCEIVER		1.0000	EACH	
1		IN		376-0178-	IC 75322 2 TTL TO MCS DRIVER		2.0000	EACH	
1		IN		376-0183-	IC 74173 4 BIT D TYPE REG 3 STATE	EC7307	3.0000	EACH	
1		IN		376-0192-	IC 74LS367 HEX BUS DRIVER 3 STATE	EC7307	10.0000	EACH	
1		IN		376-0279-	IC 8T28 4 BUS REC W/NON INV TRI OUT		2.0000	EACH	
1		IN		376-9003-	IC 24 PIN SOCKET BURNOY	EC7307	1.0000	EACH	
1		IN		376-9014-	IC 18 PIN SOCKET		36.0000	EACH	
1		IN		510-7354-	7354 PCB 928 TCP MEMORY		1.0000	EACH	

B-2

MRO08C-A

M U L T I - L E V E L B I L L O F M A T E R I A L A S O F

RUN DATE: 07/17/78

PAGE 1

ASSEMBLY PART NUMBER 209-7355- - -  
 ASSEMBLY DESCRIPTION 7355 W/UNLOADED SOCKETS

LEGEND  
 1: P=PHANTOM; 2: ITEM MASTER DELY CODE; 3: \*=TAGGED OUT OF KIT(PROD STR)

POSITION IN STRUCTURE	LEGEND 1 2 3	COMPONENT PART NUMBER	DESCRIPTION	F C N	QUANTITY PER ASSY	U/M	IML
1		IN 000-0001-	LABOR SUR-SYSTEMS		1.7860		
1		IN 000-0011-	LABOR QUALITY CONTROL		1.3570		
1		IN 300-1068-	CAP 68 PF 10% 500 V CERAMIC DISC	EC8375	1.0000	FACH	
1		IN 300-1900-	CAP .05 UF +80-20% 12 V CERAMIC D	PATREL	21.0000	FACH	
1		IN 300-2047-	CAP .0047 UF 10% 100 V MYLAR		1.0000	FACH	
1		IN 300-4022-	CAP 15.0 UF 20 V 10% TANT AXIAL	PATREL	4.0000	FACH	
1		IN 321-0022-	15.9744 MC CRYSTAL (25DEG .05%)		1.0000	FACH	
1		IN 325-15C3-	8 BANK ROCKER SWITCH		1.0000	FACH	
1	2	P FS * 330-2033-4B-	RES 330 OHM 1/4W 10% FIXED COMP		1.0000	EACH	
1	2	FS * 330-2033-	RES 330 OHM 1/4W 10% FIXED COMP		1.0000	FACH	
1	2	P FS * 330-2069-4B-	RES 680 OHM 1/4W 5% FIXED COMP		1.0000	FACH	
1	2	IN * 330-2069-	RES 680 OHM 1/4W 5% FIXED COMP		1.0000	FACH	
1	2	P FS * 330-3047-4B-	RES 4.7K OHM 1/4W 10% FIXED COMP	F8246B	30.0000	FACH	
1	2	FS * 330-3047-	RES 4.7K OHM 1/4W 10% FIXED COMP		1.0000	FACH	
1	2	P FS * 330-4010-4B-	RES 10K OHM 1/4W 10% FIXED COMP		10.0000	FACH	
1	2	FS * 330-4010-	RES 10K OHM 1/4W 10% FIXED COMP		1.0000	FACH	
1	2	P FS * 330-6028-4B-	RES 2.7M OHM 1/4W 5% FIXED COMP		1.0000	EACH	
1	2	IN * 330-6028-	RES 2.7M OHM 1/4W 5% FIXED COMP		1.0000	FACH	
1		IN 375-0017-	TSTR 2N3014 360MW 40V SH NPN S 52		1.0000	FACH	
1		IN 375-90C4-	TRANSIPAD TO-18 (SMALL)		1.0000	FACH	
1		IN 376-0002-	IC 7400N 4 2 IN POS NAND GATE		2.0000	FACH	
1		IN 376-0005-	IC 7473N 2 J-K MA-SLAVE FLIP-FLOP	PATREL	1.0000	FACH	
1		IN 376-0006-	IC 7474N 2 D EDGE TRIG FLIP-FLOP	EC7312	2.0000	FACH	
1		IN 376-0008-	IC 7442N 4 LINE-10 LINE DECODER		2.0000	FACH	
1		IN 376-0010-	IC 7404N HFX INVERTER		2.0000	FACH	
1		IN 376-0011-	IC 7493N 4 BIT BINARY COUNTER	EC7312	1.0000	EACH	
1		IN 376-0048-	IC 74153 2 4-1 LINE DATA SEL MX		2.0000	EACH	
1		IN 376-0049-	IC 74155 2 2-4 LINE DECODER DEMX	EC7312	2.0000	FACH	
1		IN 376-0050-	IC 74180 8 BIT ODD/EVEN PARITY GEN		1.0000	EACH	
1		IN 376-0081-	IC 7409 4 2 IN POS AND GATE	EC7312	2.0000	FACH	
1		IN 376-0093-	IC 7432 4 2 IN OR GATE		1.0000	EACH	
1		IN 376-0094-	IC 74161 SYNCHRONOUS 4 BIT COUNTER	EC7312	3.0000	FACH	
1		IN 376-0102-	IC 74164 8 BIT SER TO PAR CONVERTER		1.0000	EACH	
1		IN 376-0119-	IC 74175 4 D TYPE EDGE TRIG F/F		2.0000	FACH	
1		IN 376-0126-	IC 555 TIMER		1.0000	EACH	
1		IN 376-0153-	IC 74LS08 4 2 IN POS AND GATE		1.0000	FACH	
1		IN 376-0160-	IC 74LS175 4 D TYPE EDGE TRIG F/F		1.0000	FACH	
1		IN 376-0171-	IC 74148 8-3 LINE PRIORITY ENCODER		1.0000	EACH	
1		IN 376-0192-	IC 74LS367 HEX BUS DRIVER 3 STATE	EC7312	6.0000	FACH	
1		IN 376-0193-	IC 74LS368 HEX BUS DRIVER 3 STATE		2.0000	FACH	
1		IN 376-0202-	IC 74S74 2 D TYPE F F W PRESET CLER	PATREL	4.0000	EACH	
1		IN 376-9002-T	IC 16 PIN SOCKET LOW PROFILE T1	EC7647	1.0000	FACH	
1		IN 376-90C3-	IC 24 PIN SOCKET BURNDY	EC7612	1.0000	FACH	
1		IN 376-9005-	IC 16 PIN SOCKET CAMBION	EC7647	1.0000	FACH	
1		IN 376-9008-	IC 16 PIN TEKAA #4330	EC7647	1.0000	FACH	
1		IN 376-9011-	IC 40 PIN SOCKET BURNDY # D1LBZ40P1		1.0000	FACH	
1		IN 376-9015-	IC 28 PIN SOCKET BURNDY	EC7312	1.0000	FACH	

B-3

MRO08C-A      M U L T I - L E V E L    B I L L    O F    M A T E R I A L    A S    O F      R U N    D A T E :    0 7 / 1 7 / 7 8      P A G E      2

ASSEMBLY PART NUMBER 209-7355- - -      L E G E N D  
 ASSEMBLY DESCRIPTION 7355 W/LNLOADED SOCKETS      1: P=PHANTOM; 2: ITEM MASTER DELY CODE; 3: \*=TAGGED OUT OF KIT(PROD STR)

POSITION IN STRUCTURE	LEGEND 1 2 3	COMPONENT PART NUMBER	DESCRIPTION	E C N	QUANTITY PER ASSY	U/M	IML
1	IN	510-7355- - -	7355 PRINTED CIRCUIT BD		1.0000	EACH	

B-4

POSITION IN STRUCTURE	LEGEND 1 2 3	COMPONENT PART NUMBER	DESCRIPTION	E C N	QUANTITY PER ASSY	U/M	IML
1		IN 000-0001- - -	LABOR SUB-SYSTEMS		1.8340		
1		IN 000-0011- - -	LABOR QUALITY CONTROL		.3670		
1		IN 300-1900- - -	CAP .05 UF +80-20% 12 V CERAMIC D	EC7647	21.0000	FACH	
1		IN 300-1903- - -	CAP .01 UF +80-20% 25 V CERAMIC D	E7836A	1.0000	FACH	
1		IN 300-4022- - -	CAP 15.0 UF 20 V 10% TANT AXIAL	EC7647	3.0000	FACH	
1	P	FS * 330-1068-4B- - -	RES 68 OHM 1/4W 10% FIXED COMP		1.0000	FACH	
2		IN * 330-1068- - -	RES 68 OHM 1/4W 10% FIXED COMP		1.0000	FACH	
1	P	FS * 330-2018-4B- - -	RES 180 OHM 1/4W 10% FIXED COMP		3.0000	FACH	
2		FS * 330-2018- - -	RES 180 OHM 1/4W 10% FIXED COMP		1.0000	FACH	
1	P	FS * 330-2033-4B- - -	RES 330 OHM 1/4W 10% FIXED COMP		2.0000	FACH	
2		FS * 330-2033- - -	RES 330 OHM 1/4W 10% FIXED COMP		1.0000	FACH	
1	P	FS * 330-3010-4B- - -	RES 1K OHM 1/4W 10% FIXED COMP		6.0000	FACH	
2		FS * 330-3010- - -	RES 1K OHM 1/4W 10% FIXED COMP		1.0000	FACH	
1	P	FS * 330-3047-4B- - -	RES 4.7K OHM 1/4W 10% FIXED COMP		2.0000	FACH	
2		FS * 330-3047- - -	RES 4.7K OHM 1/4W 10% FIXED COMP		1.0000	FACH	
1	P	FS * 330-4010-4B- - -	RES 10K OHM 1/4W 10% FIXED COMP		1.0000	FACH	
2		FS * 330-4010- - -	RES 10K OHM 1/4W 10% FIXED COMP		1.0000	FACH	
1		IN 331-2012- - -	RES 120 OHM 1/2W 10% FIXED COMP	E7836A	2.0000	FACH	
1		IN 375-1012- - -	MPS 6512 SILICON TRANSISTOR	E7836A	1.0000	FACH	
1		IN 375-1014- - -	MPS 6518 SILICON TRANSISTOR	E7836A	1.0000	FACH	
1		IN 376-0006- - -	IC 7474N 2 D EDGE TRIG FLIP-FLOP	E7836A	1.0000	FACH	
1		IN 376-0055- - -	IC 7406 HEX INV BUF DRIVERS HV OUT	EC7647	1.0000	FACH	
1		IN 376-0076- - -	IC 75150P 2 LINE DRIVER		5.0000	FACH	
1		IN 376-0077- - -	IC 75154 4 LINE REC		3.0000	FACH	
1		IN 376-0081- - -	IC 7408 4 2 IN POS AND GATE		1.0000	FACH	
1		IN 376-0082- - -	IC 74157 4 2 IN MX		1.0000	FACH	
1		IN 376-0093- - -	IC 7432 4 2 IN OR GATE		1.0000	FACH	
1		IN 376-0098- - -	IC 74174 HEX D TYPE FLIP FLOP	EC7647	1.0000	FACH	
1		IN 376-0176- - -	IC 74367 HEX BUFFFR	EC8468	1.0000	FACH	
1		IN 376-0179- - -	IC 74368 HEX BUS DR W/3 STATE OUT	EC8468	1.0000	FACH	
1		IN 376-0192- - -	IC 74LS367 HEX BUS DRIVER 3 STATE		1.0000	FACH	
1		IN 376-0207- - -	IC 74LS00 4 2 IN POS NAND GATE	FC7836	1.0000	FACH	
1		IN 376-9015- - -	IC 28 PIN SOCKET BURNDY		1.0000	FACH	
1		IN 510-7356- - -	7356 PCB 928 TCP MODEM & ALU INTRF		1.0000	FACH	

B-5

ASSEMBLY PART NUMBER 210-7353- - -  
 ASSEMBLY DESCRIPTION 7353 MODULE (PRELIMINARY)

LEGEND  
 1: P=PHANTOM; 2: ITEM MASTER DELY CODE; 3: \*=TAGGED OUT OF KIT(PROD STP)

POSITION IN STRUCTURE	LEGEND			COMPONENT PART NUMBER	DESCRIPTION	E C N	QUANTITY PER ASSY	U/M	IML
	1	2	3						
1				IN 000-0001- - -	LABOR SUB-SYSTEMS		2.2840		
1				IN 000-0011- - -	LABOR QUALITY CONTROL		.4570		
1				IN 300-1220- - -	CAP 220 PF 10% 500 V CERAMIC DISC	EC8192	2.0000	EACH	
1				IN 300-1900- - -	CAP .05 UF +80-20% 12 V CERAMIC D	EC7647	30.0000	FACH	
1				IN 300-1903- - -	CAP .01 UF +80-20% 25 V CERAMIC D		1.0000	FACH	
1				IN 300-1906- - -	CAP .001 UF 10% 500 V CERAMIC DISC		1.0000	FACH	
1				IN 300-1930- - -	.1 UF 50V +80-20% CERAMIC CAP(HIFRQ	EC7333	1.0000	FACH	
1				IN 300-3010- - -	CAP 50 UF 50V -10+75% ELECT AXIAL		1.0000	FACH	
1				IN 300-4022- - -	CAP 15.0 UF 20 V 10% TANT AXIAL	EC7647	5.0000	EACH	
1				IN 300-5012- - -	CAP .0022UF 5% 500 V MICA DIPPED		1.0000	EACH	
1				IN 321-0018- - -	17.1 MHZ OSCILLATOR		1.0000	EACH	
1				IN 325-15C1- - -	5 BANK ROCKER SW.		1.0000	FACH	
1				P FS * 330-1092-4B- - -	RES 91 OHM 1/4W 5% FIXED COMP		1.0000	FACH	
2				FS * 330-1092- - -	RES 91 OHM 1/4W 5% FIXED COMP		1.0000	FACH	
1				P FS * 330-2011-4B- - -	RES 100 OHM 1/4W 5% FIXED COMP		1.0000	FACH	
2				FS * 330-2011- - -	RES 100 OHM 1/4W 5% FIXED COMP		1.0000	FACH	
1				P FS * 330-2028-4B- - -	RES 270 OHM 1/4W 5% FIXED COMP		1.0000	EACH	
2				FS * 330-2028- - -	RES 270 OHM 1/4W 5% FIXED COMP		1.0000	EACH	
1				P FS * 330-2040-4B- - -	RES 390 OHM 1/4W 5% FIXED COMP		1.0000	FACH	
2				FS * 330-2040- - -	RES 390 OHM 1/4W 5% FIXED COMP		1.0000	FACH	
1				P FS * 330-2047-4B- - -	RES 470 OHM 1/4W 10% FIXED COMP		2.0000	FACH	
2				FS * 330-2047- - -	RES 470 OHM 1/4W 10% FIXED COMP		1.0000	EACH	
1				P FS * 330-3022-4B- - -	RES 2.2K OHM 1/4W 10% FIXED COMP		3.0000	EACH	
2				FS * 330-3022- - -	RES 2.2K OHM 1/4W 10% FIXED COMP		1.0000	FACH	
1				P FS * 330-3027-4B- - -	RES 2.7K OHM 1/4W 10% FIXED COMP		1.0000	EACH	
2				FS * 330-3027- - -	RES 2.7K OHM 1/4W 10% FIXED COMP		1.0000	FACH	
1				P FS * 330-4010-4B- - -	RES 10K OHM 1/4W 10% FIXED COMP		3.0000	EACH	
2				FS * 330-4010- - -	RES 10K OHM 1/4W 10% FIXED COMP		1.0000	EACH	
1				P FS * 330-4034-4B- - -	RES 33K OHM 1/4W 5% FIXED COMP		1.0000	FACH	
2				FS * 330-4034- - -	RES 33K OHM 1/4W 5% FIXED COMP		1.0000	EACH	
1				P FS * 330-4047-4B- - -	RES 47K OHM 1/4W 10% FIXED COMP		1.0000	FACH	
2				FS * 330-4047- - -	RES 47K OHM 1/4W 10% FIXED COMP		1.0000	FACH	
1				IN 333-0806- - -	RES 2.2K OHM SIP 7/PER PKG	PATREI	5.0000	EACH	
1				IN 376-0002- - -	IC 7400N 4 2 IN POS NAND GATE		4.0000	FACH	
1				IN 376-0003- - -	IC 7410N 3 3 IN POS NAND GATE		1.0000	EACH	
1				IN 376-0004- - -	IC 7420N 2 4 IN POS NAND GATE		1.0000	EACH	
1				IN 376-0006- - -	IC 7474N 2 D EDGE TRIG FLIP-FLOP	EC7333	5.0000	FACH	
1				IN 376-0010- - -	IC 7404N HEX INVERTER		3.0000	FACH	
1				IN 376-0016- - -	IC 7402N 4 2 IN POS NOR GATE		1.0000	FACH	
1				IN 376-0050- - -	IC 74180 8 BIT ODD/EVEN PARITY GEN		2.0000	EACH	
1				IN 376-0053- - -	IC 74193 SYN 4 BIT UP DOWN COUNTER		1.0000	FACH	
1				IN 376-0081- - -	IC 7409 4 2 IN POS AND GATE		3.0000	FACH	

ASSEMBLY PART NUMBER 210-7353- - -  
 ASSEMBLY DESCRIPTION 7353 MODULE (PRELIMINARY)

LEGEND  
 1: P=PHANTOM; 2: ITFM MASTER DELY CODE; 3: \*=TAGGED OUT OF KIT (PROD STP)

POSITION STRUCTURE	IN	LEGEND			COMPONENT PART NUMBER	DESCRIPTION	E C N	QUANTITY PER ASSY	U/M	IML
		1	2	3						
1	IN				376-0093- - -	IC 7432 4 2 IN OR GATE	EC7719	4.0000	FACH	
1	IN				376-0094- - -	IC 74161 SYNCHRONOUS 4 BIT COUNTER	EC7408	2.0000	FACH	
1	IN				376-0097- - -	IC 74195 4 BIT PAR ACCESS SHIFT REG		4.0000	FACH	
1	IN				376-0098- - -	IC 74174 HEX D TYPE FLIP FLOP		1.0000	FACH	
1	IN				376-01C4- - -	IC 9602 2 RETRIG RESET MONOSTBL MVB	EC7333	3.0000	FACH	
1	IN				376-0138- - -	IC 74298 4 2 IN MX W/STORAGE		2.0000	FACH	
1	IN				376-0146- - -	IC 75107 2 LINE REC FIVER		1.0000	FACH	
1	IN				376-0176- - -	IC 74367 HEX BUFFER	EC7647	1.0000	FACH	
1	IN				376-0183- - -	IC 74173 4 BIT D TYPE REG 3 STATE		4.0000	FACH	
1	IN				376-0194- - -	IC 74113 3 3 IN POS AND GATE		2.0000	FACH	
1	IN				376-0197- - -	IC 74504 HEX INVERTER		1.0000	FACH	
1	IN				376-02C2- - -	IC 74574 2 D TYPE F F W PRESET CLR		3.0000	FACH	
1	IN				376-0228- - -	IC 74500 4 2 IN POS NAND GATE	EC7647	1.0000	FACH	
1	IN				376-0233- - -	IC 74LS161 SYN CTR DIRECT CLEAR	EC7408	1.0000	EACH	
1	IN				376-0237- - -	IC 74511 3 3 IN POS AND GATE		1.0000	FACH	
1	IN				376-0238- - -	IC 74510 3 3 IN POS NAND GATE		1.0000	FACH	
1	IN				376-0256- - -	IC 75113 2 DIF LINE REC 3 STATE OUT		1.0000	FACH	
1	P FS *				380-1001-4R- - -	D035 SIL DIODE 30V, 100MA AT IV .48	EC7647	1.0000	FACH	
2	FS				380-1001-R - - -	D035 SIL DIODE 30V, 100MA AT IV TCR		1.0000	FACH	
1	IN				510-7353- - -	7353 PRINTED CIRCUIT BOARD		1.0000	FACH	



ASSEMBLY PART NUMBER 210-7354-A - -  
 ASSEMBLY DESCRIPTION PCB ASSY 928 TCP MEMORY

LEGEND  
 1: P=PHANTOM; 2: ITEM MASTER DELY CODE; 3: \*=TAGGED OUT OF KIT(PROD STR)

POSITION IN STRUCTURE	LEGEND 1 2 3	COMPONENT PART NUMBER	DESCRIPTION	F C N	QUANTITY PER ASSY	U/M IML
1		IN 209-7354-- --	PCB ASSY 928 TCP MEMORY		1.0000	EACH
2		IN 000-0001-- --	LABOR SUR-SYSTEMS		1.9570	
2		IN 000-0011-- --	LABOR QUALITY CONTROL		.3910	
2		IN 300-1900-- --	CAP .05 UF +80-20% 12 V CERAMIC D	PATREL	11.0000	EACH
2		IN 300-1930-- --	.1 UF 50V +80-20% CERAMIC CAP(HIFRQ	EC7611	20.0000	EACH
2		IN 300-1931-- --	1 UF CERAMIC CAPACITOR(HIGH FREQ)		18.0000	EACH
2		IN 300-4017-- --	CAP 5.6 UF 35 V 10% TANT AXIAL	PATREL	4.0000	EACH
2		IN 300-4018-- --	CAP 18.0 UF 15 V 10% TANT AXIAL	PATREL	2.0000	EACH
2		IN 300-4022-- --	CAP 15.0 UF 20 V 10% TANT AXIAL	PATREL	3.0000	EACH
2	P	FS * 330-1011-4B--	RES 10 OHM 1/4W 5% FIXED COMP		4.0000	EACH
3	FS	* 330-1011-- --	RES 10 OHM 1/4W 5% FIXED COMP		1.0000	EACH
2	P	FS * 330-3022-4B--	RES 2.2K OHM 1/4W 10% FIXED COMP		11.0000	EACH
3	FS	* 330-3022-- --	RES 2.2K OHM 1/4W 10% FIXED COMP		1.0000	EACH
2		IN 375-1050-- --	TRANSISTOR SPS6551		4.0000	EACH
2		IN 376-0002-- --	IC 7400N 4 2 IN POS NAND GATE		1.0000	EACH
2		IN 376-0010-- --	IC 7404N HEX INVERTER		1.0000	EACH
2		IN 376-0011-- --	IC 7493N 4 BIT BINARY COUNTER		2.0000	EACH
2		IN 376-0049-- --	IC 74155 2 2-4 LINE DECODER DEMX	EC7307	1.0000	EACH
2		IN 376-0093-- --	IC 7432 4 2 IN OR GATE		1.0000	EACH
2		IN 376-0175-- --	IC 8T26 3 STATE 4 BUS TRANSCEIVER		1.0000	EACH
2		IN 376-0178-- --	IC 75322 2 TTL TO MOS DRIVER		2.0000	EACH
2		IN 376-0183-- --	IC 74173 4 BIT D TYPE REG 3 STATE	EC7307	3.0000	EACH
2		IN 376-0192-- --	IC 74LS367 HEX BUS DRIVER 3 STATE	EC7307	10.0000	EACH
2		IN 376-0279-- --	IC 8T28 4 BUS REC W/NON INV TRI OUT		2.0000	EACH
2		IN 376-9003-- --	IC 24 PIN SOCKET BURNDY	EC7307	1.0000	EACH
2		IN 376-9014-- --	IC 18 PIN SOCKET		36.0000	EACH
2		IN 510-7354-- --	7354 PCB 928 TCP MEMORY		1.0000	EACH
1	WC	377-0314-- --	TMS4050 RAM 4K (18 PIN)		36.0000	EACH
1	FS	377-0317-- --	2708 INTEL PROM	EC7307	1.0000	EACH

ASSEMBLY PART NUMBER 210-7355-A - -  
 ASSEMBLY DESCRIPTION 7355A MCDULE (PRELIMINARY)

LEGEND  
 1: P=PHANTOM; 2: ITEM MASTER DELY CODE; 3: \*=TAGGED OUT OF KIT(PROD STR)

POSITION IN STRUCTURE	LEGEND			COMPONENT PART NUMBER	DESCRIPTION	E C N	QUANTITY PER ASSY	U/M	IMI
	1	2	3						
1				IN 209-7355-	7355 W/UNLOADED SOCKETS		1.0000	FACH	
2				IN 000-0001-	LABOR SUR-SYSTEMS		1.7860		
2				IN 000-0011-	LABOR QUALITY CONTROL		1.3570		
2				IN 300-1068-	CAP 68 PF 10% 500 V CERAMIC DISC	EC8375	1.0000	EACH	
2				IN 300-19C0-	CAP .05 UF +80-20% 12 V CERAMIC D	PATREL	21.0000	FACH	
2				IN 300-2047-	CAP .0047 UF 10% 100 V MYLAR		1.0000	FACH	
2				IN 300-4022-	CAP 15.0 UF 20 V 10% TANT AXIAL	PATREL	4.0000	FACH	
2				IN 321-0022-	15.9744 MC CRYSTAL (25DEG .05%)		1.0000	FACH	
2				IN 325-15C4-	8 BANK ROCKER SWITCH		1.0000	FACH	
2				P FS * 330-2033-4B-	RES 330 OHM 1/4W 10% FIXED COMP		1.0000	FACH	
3				FS * 330-2033-	RES 330 OHM 1/4W 10% FIXED COMP		1.0000	FACH	
2				P FS * 330-2069-4B-	RES 680 OHM 1/4W 5% FIXED COMP		1.0000	FACH	
3				IN * 330-2069-	RES 680 OHM 1/4W 5% FIXED COMP		1.0000	FACH	
2				P FS * 330-3047-4B-	RES 4.7K OHM 1/4W 10% FIXED COMP	E8246B	30.0000	FACH	
3				FS * 330-3047-	RES 4.7K OHM 1/4W 10% FIXED COMP		1.0000	FACH	
2				P FS * 330-4010-4B-	RES 10K OHM 1/4W 10% FIXED COMP		10.0000	FACH	
3				FS * 330-4010-	RES 10K OHM 1/4W 10% FIXED COMP		1.0000	FACH	
2				P FS * 330-6028-4B-	RES 2.7M OHM 1/4W 5% FIXED COMP		1.0000	FACH	
3				IN * 330-6028-	RES 2.7M OHM 1/4W 5% FIXED COMP		1.0000	FACH	
2				IN 375-0017-	TSTR 2N3014 360MW 40V SH NPN S 52		1.0000	FACH	
2				IN 375-9004-	TRANSIPAD TO-18 (SMALL)		1.0000	FACH	
2				IN 376-0002-	IC 7400N 4 2 IN POS NAND GATE		2.0000	FACH	
2				IN 376-0005-	IC 7473N 2 J-K MA-SLAVE FLIP-FLOP	PATREL	1.0000	FACH	
2				IN 376-0006-	IC 7474N 2 D EDGE TRIG FLIP-FLOP	EC7312	2.0000	FACH	
2				IN 376-0008-	IC 7442N 4 LINE-10 LINE DECODER		2.0000	FACH	
2				IN 376-0010-	IC 7404N HEX INVERTER		2.0000	FACH	
2				IN 376-0011-	IC 7493N 4 BIT BINARY COUNTER	EC7312	1.0000	FACH	
2				IN 376-0048-	IC 74153 2 4-1 LINE DATA SEL MX		2.0000	FACH	
2				IN 376-0049-	IC 74155 2 2-4 LINE DECODER DEMX	EC7312	2.0000	FACH	
2				IN 376-0050-	IC 74180 8 BIT ODD/EVEN PARITY GEN		1.0000	FACH	
2				IN 376-0081-	IC 7408 4 2 IN POS AND GATE	EC7312	2.0000	FACH	
2				IN 376-0093-	IC 7432 4 2 IN OR GATE		1.0000	FACH	
2				IN 376-0094-	IC 74161 SYNCHRONOUS 4 BIT COUNTER	EC7312	3.0000	FACH	
2				IN 376-0102-	IC 74164 8 BIT SER TO PAR CONVERTER		1.0000	FACH	
2				IN 376-0119-	IC 74175 4 D TYPE EDGE TRIG F/F		2.0000	FACH	
2				IN 376-0126-	IC 555 TIMER		1.0000	FACH	
2				IN 376-0153-	IC 74LS08 4 2 IN POS AND GATE		1.0000	FACH	
2				IN 376-0160-	IC 74LS175 4 D TYPE EDGE TRIG F/F		1.0000	FACH	
2				IN 376-0171-	IC 74148 8-3 LINE PRIORITY ENCODER		1.0000	FACH	
2				IN 376-0192-	IC 74LS367 HEX BUS DRIVER 3 STATE	EC7312	6.0000	FACH	
2				IN 376-0193-	IC 74LS368 HEX BUS DRIVER 3 STATE		2.0000	FACH	
2				IN 376-0202-	IC 74S74 2 D TYPE F F W PRESET CLR	PATREL	4.0000	FACH	
2				IN 376-9002-T	IC 16 PIN SOCKET LOW PROFILE T1	EC7647	1.0000	FACH	
2				IN 376-9003-	IC 24 PIN SOCKET BURNDY	EC7612	1.0000	FACH	
2				IN 376-9005-	IC 16 PIN SOCKET CAMBION	EC7647	1.0000	FACH	
2				IN 376-9008-	IC 16 PIN TFKNA #4330	EC7647	1.0000	FACH	
2				IN 376-9011-	IC 40 PIN SOCKET BURNDY # DILBZ40P1		1.0000	FACH	

ASSEMBLY PART NUMBER 210-7355-A - -  
 ASSEMBLY DESCRIPTION 7355A MCEULE (PRELIMINARY)

LEGEND  
 1: P=PHANTOM; 2: ITEM MASTER DELY CODE; 3: \*=TAGGED OUT OF KIT(PROD STR)

POSITION STRUCTURE	IN	LEGEND			COMPONENT PART NUMBER	DESCRIPTION	F C N	QUANTITY PER ASSY	U/M	IMI
		1	2	3						
2		IN			376-9015- - -	IC 28 PIN SOCKET BURNDY	EC7312	1.0000	FACH	
2		IN			510-7355- - -	7355 PRINTED CIRCUIT BD		1.0000	FACH	
1		WC			377-0269- - -	8080A MICROPROCESSOR		1.0000	FACH	
1		WC			377-0337- - -	8224 I.C.		1.0000	EACH	
1		WC			377-0338- - -	8228 I.C.		1.0000	FACH	
1		IN			377-0340- - -	8214 PRIORITY INTERRUPT CNTL UNIT	EC7312	1.0000	FACH	

ASSEMBLY PART NUMBER 210-7356- - -      LEGEND  
 ASSEMBLY DESCRIPTION 7356 MODEM & ALU INTERFC (INACTIVE)      1: P=PHANTOM; 2: ITEM MASTER DELY CODE; 3: \*=TAGGED OUT OF KIT(PROD STR)

POSITION IN STRUCTURE	LEGEND			COMPONENT PART NUMBER	DESCRIPTION	E C N	QUANTITY PER ASSY	U/M	IML
	1	2	3						
1		IN		000-0001- - -	LABOR SUB-SYSTEMS		2.5000		
1		IN		000-0011- - -	LABOR QUALITY CONTROL		5.5000		
1		P FS *		330-3010-48- - -	RES 1K OHM 1/4W 10% FIXED COMP		5.0000	FACH	
2		FS *		330-3010- - -	RES 1K OHM 1/4W 10% FIXED COMP		1.0000	FACH	
1		IN		376-0076- - -	IC 75150P 2 LINE DRIVER		5.0000	FACH	
1		IN		376-0077- - -	IC 75154 4 LINE RFC		3.0000	FACH	
1		IN		376-0159- - -	IC 74LS174 HEX D TYPE FLIP FLOP		1.0000	FACH	
1		IN		376-0176- - -	IC 74367 HEX BUFFER	EC8468	1.0000	FACH	
1		IN		376-0179- - -	IC 74368 HEX BUS DR W/3 STATE OUT	EC8468	1.0000	EACH	
1		IN		376-9016- - -	IC 24 PIN SOCKET CAMBION	PATREL	1.0000	EACH	
1		IN		510-7356- - -	7356 PCB 928 TCP MODEM & ALU INTRF		1.0000	EACH	

POSITION IN STRUCTURE	LEGEND			CCMFCNT PART NUMBER	DESCRIPTION	E C N	QUANTITY PER ASSY	U/M	IML
	1	2	3						
1				IN 209-7356- - -	PCB ASSY 928 TCP MODEM & ALU INTRF		1.0000	EACH	
2				IN 000-0001- - -	LABOR SUB-SYSTEMS		1.8340		
2				IN 000-0011- - -	LABOR QUALITY CONTROL		.3670		
2				IN 300-1900- - -	CAP .05 UF +80-20% 12 V CERAMIC D	EC7647	21.0000	FACH	
2				IN 300-1903- - -	CAP .01 UF +80-20% 25 V CERAMIC D	F7836A	1.0000	FACH	
2				IN 300-4922- - -	CAP 15.0 UF 20 V 10% TANT AXIAL	EC7647	3.0000	FACH	
3		P	FS *	330-1068-4B- - -	RES 68 OHM 1/4W 10% FIXED COMP		1.0000	FACH	
3		IN *		330-1068- - -	RES 68 OHM 1/4W 10% FIXED COMP		1.0000	FACH	
2		P	FS *	330-2018-4B- - -	RES 180 OHM 1/4W 10% FIXED COMP		3.0000	FACH	
3		FS *		330-2018- - -	RES 180 OHM 1/4W 10% FIXED COMP		1.0000	FACH	
2		P	FS *	330-2033-4B- - -	RES 330 OHM 1/4W 10% FIXED COMP		2.0000	FACH	
3		FS *		330-2033- - -	RES 330 OHM 1/4W 10% FIXED COMP		1.0000	FACH	
2		P	FS *	330-3010-4B- - -	RES 1K OHM 1/4W 10% FIXED COMP		6.0000	FACH	
3		FS *		330-3010- - -	RES 1K OHM 1/4W 10% FIXED COMP		1.0000	FACH	
2		P	FS *	330-3047-4B- - -	RES 4.7K OHM 1/4W 10% FIXED COMP		2.0000	FACH	
3		FS *		330-3047- - -	RES 4.7K OHM 1/4W 10% FIXED COMP		1.0000	FACH	
2		P	FS *	330-4010-4B- - -	RES 10K OHM 1/4W 10% FIXED COMP		1.0000	FACH	
3		FS *		330-4010- - -	RES 10K OHM 1/4W 10% FIXED COMP		1.0000	FACH	
2		IN		331-2012- - -	RES 120 OHM 1/2W 10% FIXED COMP	F7836A	2.0000	FACH	
2		IN		375-1012- - -	MPS 6512 SILICON TRANSISTOR	E7836A	1.0000	FACH	
2		IN		375-1014- - -	MPS 6518 SILICON TRANSISTOR	F7836A	1.0000	FACH	
2		IN		376-0006- - -	IC 7474N 2 D EDGE TRIG FLIP-FLOP		1.0000	FACH	
2		IN		376-0055- - -	IC 7406 HEX INV BUF DRIVERS HV OUT	EC7647	1.0000	FACH	
2		IN		376-0076- - -	IC 75150P 2 LINE DRIVER		5.0000	FACH	
2		IN		376-0077- - -	IC 75154 4 LINE REC		3.0000	FACH	
2		IN		376-0081- - -	IC 7408 4 2 IN POS AND GATE		1.0000	FACH	
2		IN		376-0082- - -	IC 74157 4 2 IN MX		1.0000	FACH	
2		IN		376-0093- - -	IC 7432 4 2 IN OR GATE		1.0000	FACH	
2		IN		376-0098- - -	IC 74174 HEX D TYPE FLIP FLOP	EC7647	1.0000	FACH	
2		IN		376-0176- - -	IC 74367 HEX BUFFER	EC8468	1.0000	FACH	
2		IN		376-0179- - -	IC 74368 HEX BUS DR W/3 STATE OUT	EC8468	1.0000	FACH	
2		IN		376-0192- - -	IC 74LS367 HEX BUS DRIVER 3 STATE		1.0000	FACH	
2		IN		376-0207- - -	IC 74LS00 4 2 IN POS NAND GATE	EC7836	1.0000	FACH	
2		IN		376-9015- - -	IC 24 PIN SOCKET BURNDY		1.0000	FACH	
2		IN		510-7356- - -	7356 PCB 928 TCP MODEM & ALU INTRF		1.0000	FACH	
1		WC		377-0318- - -	8251(USART)ROM		1.0000	FACH	

B-12

MBOORC-A      M U L T I - L V E L  
 ASSEMBLY PART NUMBER 210-7357- - -  
 ASSEMBLY DESCRIPTION 7357 MODULE

B I L L   O F   M A T E R I A L   A S   O F

RUN DATE: 07/17/78

PAGE 1

LEGEND  
 1: P=PHANTCM; 2: ITEM MASTER DELY CODE; 3: \*=TAGGED OUT OF KIT(PROD STR)

POSITION IN STRUCTURE	LEGEND			COMPONENT PART NUMBER	DESCRIPTION	E C N	QUANTITY PER ASSY	U/M	IMI
	1	2	3						
1		IN		300-19C0- - -	CAP .05 UF +80-20% 12 V CERAMIC D	PATREL	1.0000	EACH	
1		IN		300-4022- - -	CAP 15.0 UF 20 V 10% TANT AXIAL	PATREL	3.0000	EACH	
1		IN		320-0062- - -	RELAY MERCURY FILM		2.0000	EACH	
1		P FS *		330-2039-4B- - -	RES 390 OHM 1/4W 10% FIXED COMP	EC8703	2.0000	EACH	
2		FS *		330-2039- - -	RES 390 OHM 1/4W 10% FIXED COMP		1.0000	EACH	
1		P FS *		330-2068-4B- - -	RES 680 OHM 1/4W 10% FIXED COMP	FC8703	1.0000	EACH	
2		FS *		330-2068- - -	RES 680 OHM 1/4W 10% FIXED COMP		1.0000	EACH	
1		P FS *		330-3010-4B- - -	RES 1K OHM 1/4W 10% FIXED COMP	EC8703	2.0000	EACH	
2		FS *		330-3010- - -	RES 1K OHM 1/4W 10% FIXED COMP		1.0000	EACH	
1		P FS *		330-3022-4B- - -	RES 2.2K OHM 1/4W 10% FIXED COMP		4.0000	EACH	
2		FS *		330-3022- - -	RES 2.2K OHM 1/4W 10% FIXED COMP		1.0000	EACH	
1		P FS *		330-3047-4B- - -	RES 4.7K OHM 1/4W 10% FIXED COMP		1.0000	EACH	
2		FS *		330-3047- - -	RES 4.7K OHM 1/4W 10% FIXED COMP		1.0000	EACH	
1		IN		375-0017- - -	TSTR 2N3014 360MW 40V SH NPN S 52		1.0000	EACH	
1		IN		375-1017- - -	TSTR 2N2906A 1.8W 60V SH PNP S 18		1.0000	EACH	
1		IN		375-90C4- - -	TRANSIPAD TO-18 (SMALL)		2.0000	EACH	
1		IN		376-0010- - -	IC 7404N HEX INVERTER		1.0000	EACH	
1		IN		376-0076- - -	IC 75150P 2 LINE DRIVER		1.0000	EACH	
1		IN		376-0077- - -	IC 75154 4 LINE REC		1.0000	EACH	
1		P FS *		380-1001-4B- - -	D035 SIL DIODE 30V, 100MA AT 1V +B		2.0000	EACH	
2		FS		380-1001-R - -	D035 SIL DIODE 30V, 100MA AT 1V +R		1.0000	EACH	
1		IN		380-2039- - -	D10 ZEN 1N748 A 3.9V 400MW S DO-7		1.0000	EACH	
1		FS		380-4000- - -	D10 1N4004 400V 1A RECT S DO41		2.0000	EACH	
1		IN		510-7357- - -	7357 PRINTED CIRCUIT BOARD		1.0000	EACH	

B-13

ASSEMBLY PART NUMBER 210-7358- - -  
 ASSEMBLY DESCRIPTION 7358 REGULATOR (928TCP)

LEGEND  
 1: P=PHANTOM; 2: ITEM MASTER DELY CODE; 3: \*=TAGGED OUT OF KIT(PROD STR)

POSITION IN STRUCTURE	LEGEND			COMPONENT PART NUMBER	DESCRIPTION	E C N	QUANTITY PER ASSY	U/M	IML
	1	2	3						
1				IN 000-0001- - -	LABOR SUB-SYSTEMS		1.9530		
1				IN 000-0011- - -	LABOR QUALITY CONTROL		.3910		
1				IN 300-1900- - -	CAP .05 UF +80-20% 12 V CERAMIC D		6.0000	EACH	
1				IN 300-1906- - -	CAP .001 UF 10% 500 V CERAMIC DISC		2.0000	EACH	
1				IN 300-1915- - -	CAP .0056 UF 20% 500 V CERAMIC DISC	EC 7646	4.0000	EACH	
1				IN 300-3021- - -	500 UF CAPACITOR W/OFF-76		1.0000	EACH	
1				IN 300-3078- - -	8.2K UF 25V ELECTROLYTIC CAP(AXIAL)		1.0000	EACH	
1				IN 300-4018- - -	CAP 18.0 UF 15 V 10% TANT AXIAL	PATREL	1.0000	EACH	
1				IN 300-4022- - -	CAP 15.0 UF 20 V 10% TANT AXIAL	PATREL	2.0000	EACH	
1				IN 300-4032- - -	CAP 10.0 UF 35 V 10% TANT AXIAL		1.0000	EACH	
1				P FS * 330-1022-4R- - -	RES 22 OHM 1/4W 10% FIXED COMP		1.0000	EACH	
2				IN * 330-1022- - -	RES 22 OHM 1/4W 10% FIXED COMP		1.0000	EACH	
1				P FS * 330-1027-4R- - -	RES 27 OHM 1/4W 10% FIXED COMP		1.0000	EACH	
2				IN * 330-1027- - -	RES 27 OHM 1/4W 10% FIXED COMP		1.0000	EACH	
1				P FS * 330-2068-4P- - -	RES 680 OHM 1/4W 10% FIXED COMP		1.0000	EACH	
2				FS * 330-2068- - -	RES 680 OHM 1/4W 10% FIXED COMP		1.0000	EACH	
1				P FS * 330-2082-4R- - -	RES 820 OHM 1/4W 10% FIXED COMP		1.0000	EACH	
2				FS * 330-2082- - -	RES 820 OHM 1/4W 10% FIXED COMP		1.0000	EACH	
1				P FS * 330-3010-4R- - -	RES 1K OHM 1/4W 10% FIXED COMP		1.0000	EACH	
2				FS * 330-3010- - -	RES 1K OHM 1/4W 10% FIXED COMP		1.0000	EACH	
1				P FS * 330-3015-4B- - -	RES 1.5K OHM 1/4W 10% FIXED COMP		4.0000	EACH	
2				FS * 330-3015- - -	RES 1.5K OHM 1/4W 10% FIXED COMP		1.0000	EACH	
1				P FS * 330-3018-4R- - -	RES 1.8K OHM 1/4W 10% FIXED COMP		1.0000	EACH	
2				FS * 330-3018- - -	RES 1.8K OHM 1/4W 10% FIXED COMP		1.0000	EACH	
1				P FS * 330-3022-4R- - -	RES 2.2K OHM 1/4W 10% FIXED COMP		3.0000	EACH	
2				FS * 330-3022- - -	RES 2.2K OHM 1/4W 10% FIXED COMP		1.0000	EACH	
1				P FS * 330-3027-4R- - -	RES 2.7K OHM 1/4W 10% FIXED COMP		1.0000	EACH	
2				FS * 330-3027- - -	RES 2.7K OHM 1/4W 10% FIXED COMP		1.0000	EACH	
1				P FS * 330-3033-4R- - -	RES 3.3K OHM 1/4W 10% FIXED COMP		3.0000	EACH	
2				FS * 330-3033- - -	RES 3.3K OHM 1/4W 10% FIXED COMP		1.0000	EACH	
1				P FS * 330-3056-4R- - -	RES 5.6K OHM 1/4W 10% FIXED COMP		1.0000	EACH	
2				FS * 330-3056- - -	RES 5.6K OHM 1/4W 10% FIXED COMP		1.0000	EACH	
1				P FS * 330-4033-4R- - -	RES 33K OHM 1/4W 10% FIXED COMP		1.0000	EACH	
2				FS * 330-4033- - -	RES 33K OHM 1/4W 10% FIXED COMP		1.0000	EACH	
1				P FS * 330-5010-4R- - -	RES 100K OHM 1/4W 10% FIXED COMP		1.0000	EACH	
2				FS * 330-5010- - -	RES 100K OHM 1/4W 10% FIXED COMP		1.0000	EACH	
1				P FS * 330-5012-4R- - -	120K OHM 1/4W 100/0 4 RES W/OFF-76		3.0000	EACH	
2				FS * 330-5012- - -	120K OHM 1/4W 100/0 4 RES W/OFF-76		1.0000	EACH	

B-14

POSITION IN STRUCTURE	LEGEND 1 2 3	COMPONENT PART NUMBER	DESCRIPTION	E C N	QUANTITY PER ASSY	U/M	IMI
1		IN 332-3010- - -	RES 1K OHM 1W 10% FIXED COMP		2.0000	FACH	
1		IN 334-0002- - -	15 OHM 11W FIXED RESISTOR		1.0000	FACH	
1		IN 334-00C3- - -	20 OHM 11W FIXED RESISTOR		1.0000	FACH	
1		IN 334-0014- - -	1 OHM 2.5W 5% FIXED RESISTOR		1.0000	FACH	
1		IN 334-0015- - -	.15 OHM 5W 5% FIXED RESISTOR		1.0000	FACH	
1		IN 336-1014- - -	RES 1K OHM VAR TRIM SIDE ADJ SQ	PATREL	2.0000	FACH	
1		IN 336-1022- - -	RES 2K OHM VAR TRIM SIDE ADJ SQ	PATREL	2.0000	FACH	
1		IN 337-2039- - -	RES 390 OHM 2W 10% FIXED COMP	PATREL	1.0000	FACH	
1		IN 375-1017- - -	TSTR 2N2906A 1.8W 60V SH PNP S 18		1.0000	FACH	
1		IN 375-1024- - -	TSTR 2N4234 1.0W 40V SP PNP S T05		1.0000	FACH	
1		IN 375-1052- - -	TRANSISTOR 2N6387 (PLASTIC)		2.0000	FACH	
1		IN 375-1053- - -	TRANSISTOR RCA8203A (PLASTIC)		1.0000	FACH	
1		IN 375-9001- - -	TRANSIPAD 8977887-1 LARGE		1.0000	FACH	
1		IN 375-90C4- - -	TRANSIPAD T0-18 (SMALL)		1.0000	FACH	
1		IN 375-9016- - -	MICA INSUL WDF1038 FOR 375-1034/1035	EC7646	3.0000	FACH	
1		IN 376-0066- - -	IC 723 VOLTAGE REGULATOR		2.0000	FACH	
1		IN 376-0074- - -	IC 741C OPERATIONAL AMP		1.0000	FACH	
1		IN 376-0134- - -	IC LM304 NEG VOLTAGE REGULATOR		2.0000	FACH	
1		IN 376-0240- - -	IC LM339 4 COMPARTOR	PATREL	1.0000	FACH	
1	P	FS * 380-1001-4B- - -	D035 SIL DIODE 30V, 100MA AT 1V .48		5.0000	FACH	
1		FS 380-1001-R - - -	D035 SIL DIODE 30V, 100MA AT 1V TER		1.0000	FACH	
1		IN 380-2129- - -	D10 ZEN 1N4372A 3.0V 400MW S DO-7		1.0000	FACH	
1		IN 380-30C8- - -	A15A RECTIFIER	PATREL	2.0000	FACH	
1		FS 380-40C0- - -	D10 1N4004 400V 1A RECT S D041	PATREL	2.0000	FACH	
1		IN 451-4583- - -	BRKT, TRANSISTOR (928TCP) C6850-551	EC7646	1.0000	FACH	
1		IN 510-7358- - -	7358 PRINTED CIRCUIT BOARD		1.0000	FACH	
1		FS 605-1004- - -	CABLE TYE, PAN-TY PLT1M-M	EC7646	4.0000	FACH	
1		IN 650-3080- - -	6-32 X 1/4 PAN HD PHL MS SS SEMS	EC7646	2.0000	FACH	
1		IN 650-3131- - -	6-32 X 3/8 NYLON COVERED FIL HD SLT	EC7646	3.0000	FACH	

B-15



MBO08C-A      M U L T I - L E V E L      B I L L   O F   M A T E R I A L   A S   O F

RUN DATE: 07/17/78

PAGE      1

ASSEMBLY PART NUMBER    210-7359- - -  
 ASSEMBLY DESCRIPTION    7359 MOTHER BOARD (928TCP)

LEGEND  
 1: P=PHANTOM; 2: ITEM MASTER DELY CODE; 3: \*=TAGGED OUT OF KIT(PROD STR)

POSITION IN STRUCTURE	LEGEND			COMPONENT PART NUMBER	DESCRIPTION	E C N	QUANTITY PER ASSY	U/M	IML
	1	2	3						
1		IN		000-0004- - -	SUB-SYSTEMS		1.2410	FACH	
1		IN		000-0011- - -	LABOR    QUALITY CONTROL		.2480	FACH	
1		IN		350-0011- - -	225-21521-110 PC CONN SOLDER TYPE		6.0000	FACH	
1		IN		350-0021- - -	225-22221-110 SOL TYPE	EC7630	5.0000	FACH	
1		IN		350-0039- - -	44 POS P.C.CONN SOLDER TYPE(CINCH)		4.0000	FACH	
1		IN		350-1024- - -	57-40140 CP CONN 57 SERIES    W/O-77		1.0000	FACH	
1		IN		350-1031- - -	DB-255 CH CONN 6000 SERIES		2.0000	FACH	
1		IN		350-1051- - -	CONN, 25 POS SUBMIN SKT PC TAIL	EC8930	2.0000	FACH	
1		IN		452-0097- - -	PLATE,CONNECTOR (928TCP) 86850-554	EC7630	1.0000	FACH	
1		IN		462-0211- - -	4-40 X 1/4L X 3/16D M&F SPACFP	EC7630	4.0000	FACH	
1		IN		510-7359- - -	7359 PRINTED CIRCUIT BOARD	PATREL	1.0000	FACH	
1		IN		650-1080- - -	SCR    3-48    1/4    SLOT PH MS SS	EC7630	2.0000	FACH	
1		IN		653-1000- - -	WASH    3 .109ID .2750D INT T	ST EC7630	2.0000	FACH	

END OF REPORT MBO080-A

**APPENDIX**

**C**

**SCHE-**

**MATICS**

THE SCHEMATICS, WHEN AVAILABLE, ARE ON THE LAST FICHE IN THIS SET.

**WORD  
PROCES-  
SING  
NEWS-  
LETTER  
NO.48.3A**

# CUSTOMER ENGINEERING

# ● WORD PROCESSING NEWSLETTER NO. 48.3A

CONFORM/EXECUTE	<input checked="" type="checkbox"/>
INFORMATION ONLY	<input type="checkbox"/>
	<input type="checkbox"/>

## SYSTEMS 10/20/30

July 31, 1979

### CHANGES TO WPNL #48.3

Two changes must be made to the information contained in WPNL #48.3 "WPS TELECOMMUNICATIONS BINARY SYNCHRONOUS SOFTWARE UPDATE".

The first change to be made is on page four, paragraph three. This paragraph should read as follows:

"This option, if specified, applies to all connections. Szap COM 35,0D Byte 2F from 00 to 80."

The second change to be made is on page seven, step 17. The column labeled "BYTE" should be changed as follows:

BYTE  
C4  
C5

Insert these changes in WPNL #48.3 and retain this WPNL in file.



LABORATORIES, INC.

ONE INDUSTRIAL AVENUE LOWELL MASSACHUSETTS 01851. TEL (617) 851 4111 TWX 710 343 6769. TELEX 94 7421

**WORD  
PROCES-  
SING  
NEWS-  
LETTER  
NO.48.4**

# CUSTOMER ENGINEERING

# WORD PROCESSING NEWSLETTER NO.48.4

CONFORM/EXECUTE	
INFORMATION ONLY	X

SYSTEMS 10/20/30

June 7, 1979

## WPS TELECOMMUNICATIONS BINARY SYNCHRONOUR SOFTWARE UPDATE

(Update to and correction for WPNL #48 — 19 July 1978)

RELEASE 2.XT7.3 (W.L. # 703-0139)  
RELEASE 7.XT7.3 (W.L. # 703-0141)  
RELEASE 17.XT7.3 (W.L. # 703-0140)

This release corrects a problem with the generated format lines in received documents. If the return for the format line fills in the last byte of the disk sector, the return would be lost; and the following text, up to the next return, would be appended to the format line.

This correction affects the zap for changing the format length.

To change the format length to 132 for received documents (or any length less than 159), make a patch on the COM DISK.

DISK ADDRESS	WAS	CHANGED TO
T31 SOA B4B	4E	82 (or desired length -2, in hex)
T31 SOB B3D	4E	82 (or desired length -2, in hex)
T31 SOB B44	4C	80 (or desired length -4, in hex)



LABORATORIES, INC.

ONE INDUSTRIAL AVENUE LOWELL MASSACHUSETTS 01851 TEL (617) 851 4111 TWX 710 343 6769 TELEX 94 7421

**APPENDIX**

**C**

**SCHE-**

**MATICS**



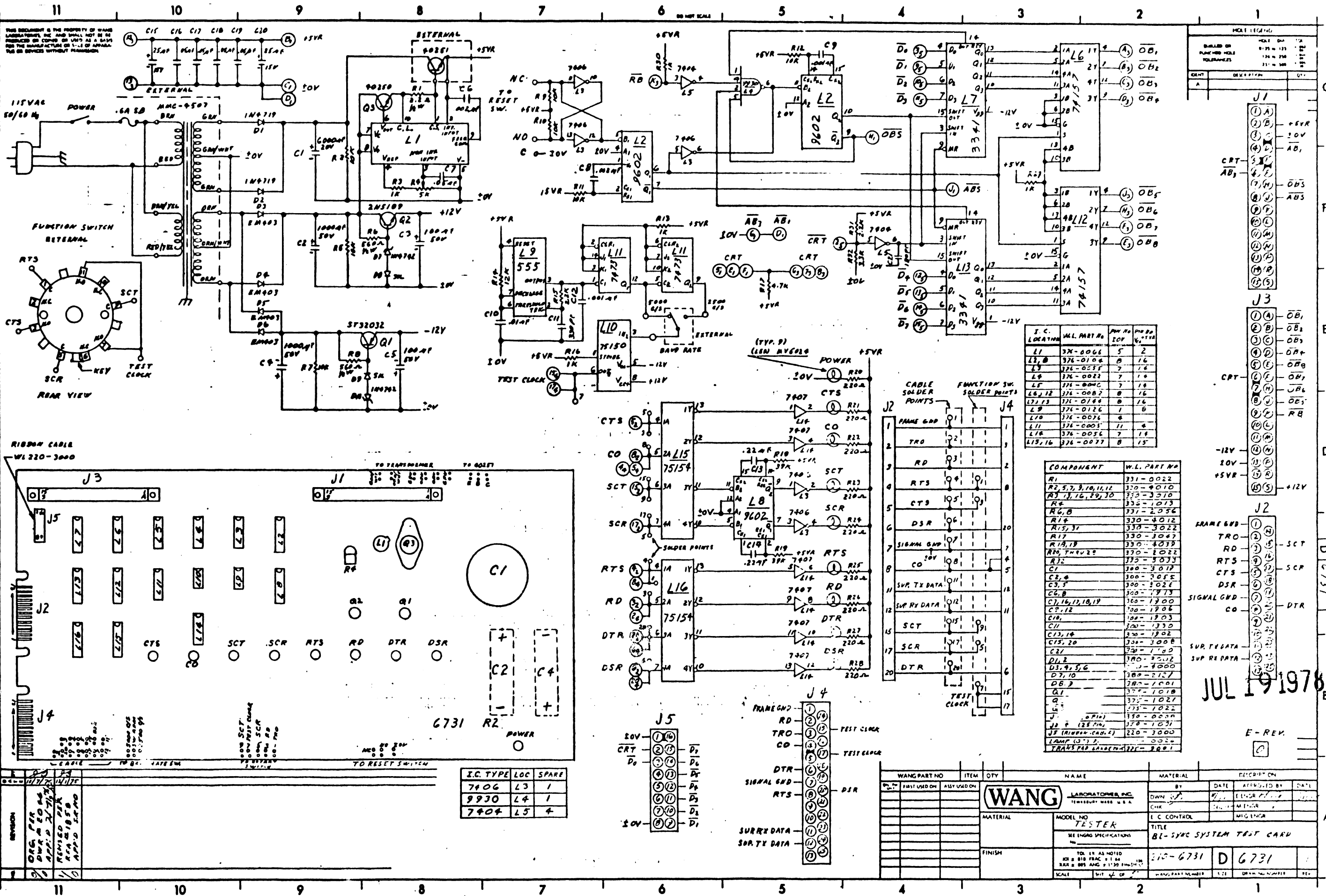
APPENDIX C

BINARY SYNCHRONOUS

COMMUNICATIONS OPTION

SCHEMATICS

210-6731	BI-SYNC SYSTEM TEST CARD
210-7353	TC DATA LINK BOARD
210-7354	MEMORY BOARD
210-7355	CPU BOARD
210-7356	MODEM AND ACU BOARD
210-7357	CURRENT LOOP INTERFACE BOARD
210-7358	TC REGULATOR BOARD
210-7359	TC MOTHERBOARD
210-7463	2228N BI-SYNC NULL MODEM



DATE LEGEND

DATE	BY	DESCRIPTION
12/15/73	...	...
12/16/73	...	...
12/17/73	...	...

I. C. LOCATION	W.L. PART NO	REV	QTY	REV
L1	376-0066	5	2	
L2, B	376-0106	8	16	
L3	376-0055	7	16	
L4	376-0022	7	16	
L5	376-0040	7	16	
L6, 12	376-0082	8	16	
L7, 13	376-0126	8	16	
L8	376-0126	1	8	
L10	376-0076	4	16	
L11	376-0005	11	4	
L14	376-0056	7	16	
L15, 16	376-0077	8	15	

COMPONENT	W.L. PART NO
R1	331-0022
R2, 5, 7, 9, 10, 11, 12	320-4010
R3, 13, 16, 29, 30	320-3070
R4	320-1013
R6, 8	331-2056
R14	330-4012
R15, 31	330-3022
R17	330-3047
R18, 18	330-4039
R19, TRV29	370-2022
R22	320-5073
C1	300-3017
C2, 4	300-3056
C3, 5	300-4026
C6, 8	300-1773
C7, 16, 17, 19	300-1900
C7, 12	300-1906
C8	300-1903
C11	300-1902
C13, 14	300-1902
C15, 20	300-3008
C21	300-1900
D1, 2	300-2012
D3, 4, 5, 6	300-4000
D7, 10	300-2157
DB, 9	300-1001
Q1	376-1018
Q2	376-1021
Q3	376-1022
J1	330-0010
J2, 8 (28 Pin)	378-1031
J3 (Tripper-Cad.)	220-3000
LAMP (3")	...
TRANS PAR (28 Pin)	3220-3001

JUL 19 1976

E-REV.

I.C. TYPE	LOC	SPARE
7406	L3	1
9930	L4	1
7404	L5	4

WANG PART NO	ITEM	QTY	NAME	MATERIAL	DESCRIPTION
...	...	...	...	...	...
			<b>WANG</b> LABORATORIES, INC. TEMPERLEY HALL U.S.A.	BY: DWN	DATE: 7/19/76
			MODEL NO: <b>TESTER</b>	CHE: ...	DATE: ...
			TITLE: <b>BI-Sync SYSTEM TEST CARD</b>	E.C. CONTROL: ...	MIG ENGR: ...
			FINISH: ...	SCALE: ...	...

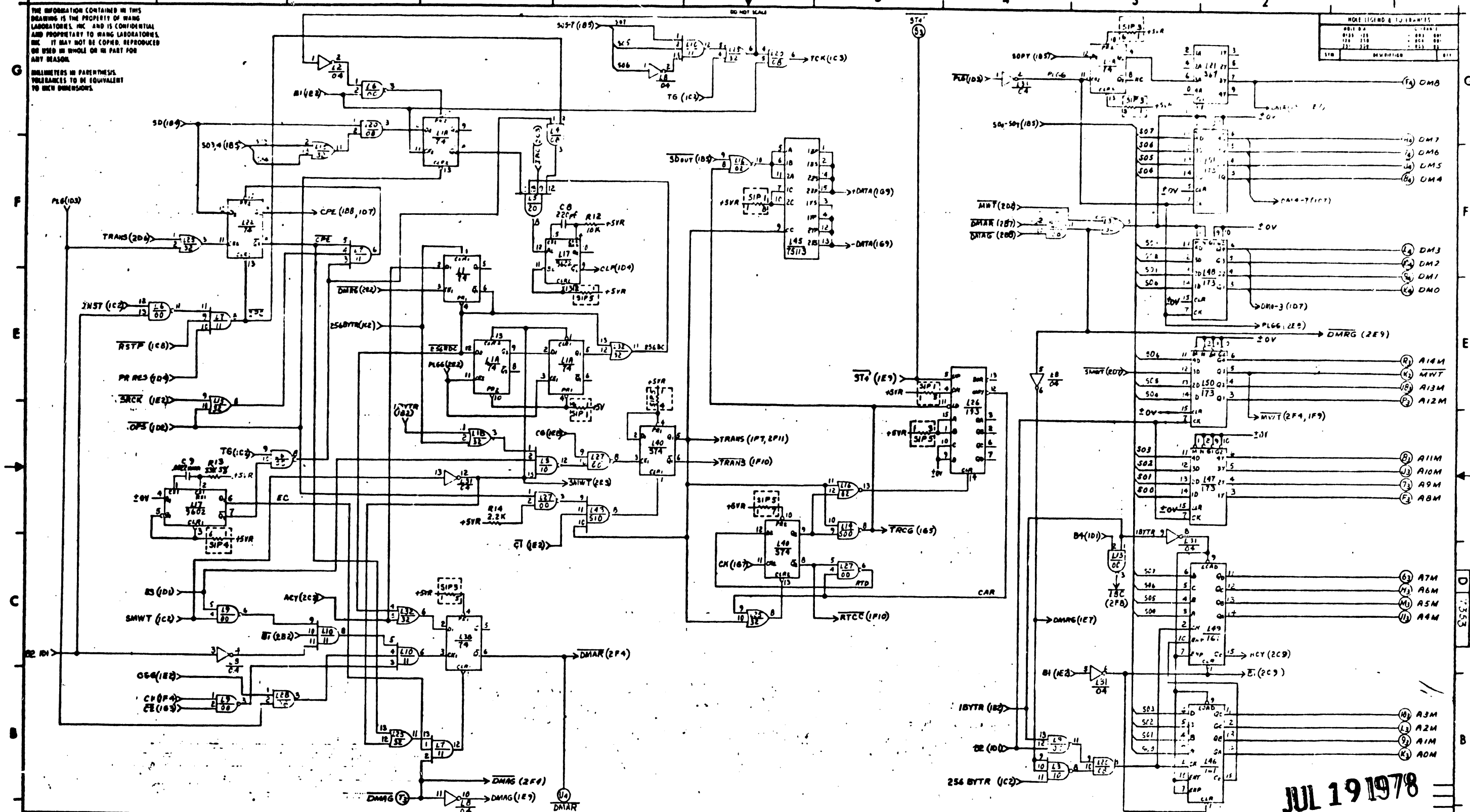
REVISION	DATE	BY	DESCRIPTION
1	11/17/73	...	...
2	11/17/73	...	...
3	11/17/73	...	...
4	11/17/73	...	...



THE INFORMATION CONTAINED IN THIS DRAWING IS THE PROPERTY OF WANG LABORATORIES, INC. AND IS CONFIDENTIAL AND PROPRIETARY TO WANG LABORATORIES, INC. IT MAY NOT BE COPIED, REPRODUCED OR USED IN WHOLE OR IN PART FOR ANY REASON.

DIMENSIONS IN PARENTHESES TOLERANCES TO BE EQUIVALENT TO NEW DIMENSIONS.

HOLE LEGEND & DIMENSIONS	
HOLE NO.	DESCRIPTION
101	1.00
102	1.00
103	1.00
104	1.00
105	1.00
106	1.00
107	1.00
108	1.00
109	1.00
110	1.00

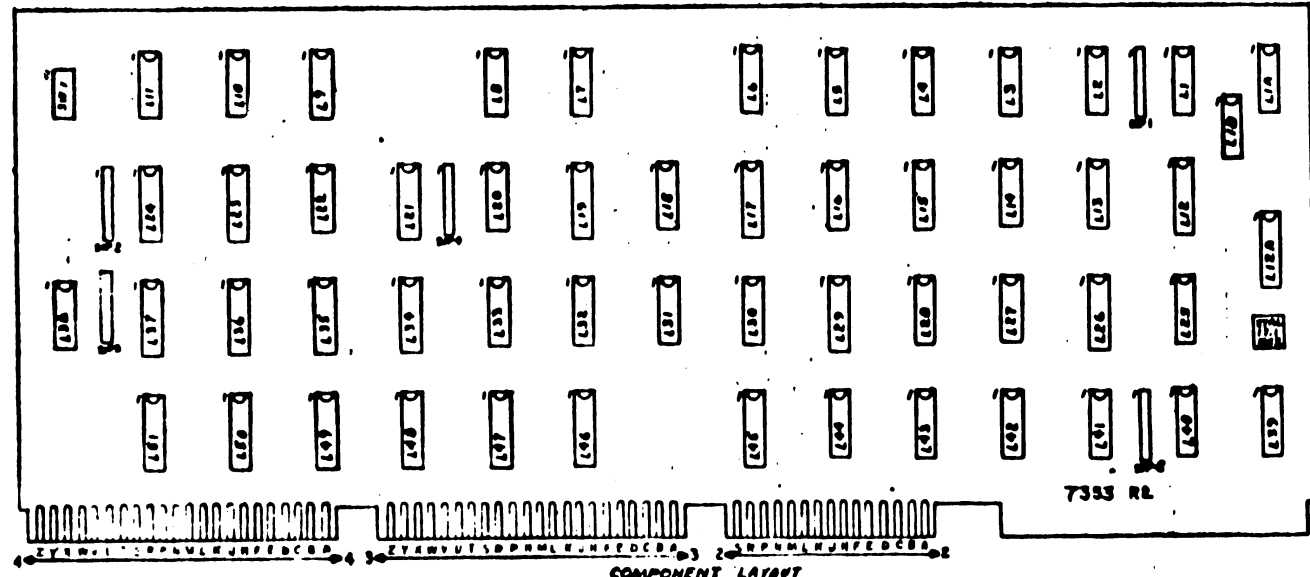


JUL 19 1978

QTY.	ITEM	WANG PART NO.	DRAWING NO.	DESCRIPTION	BY	DATE	APPROVED BY	DATE
	WANG	LABORATORIES, INC.						
	MODEL NO.	92P10P						
	TITLE	DATA TELECOMMUNICATIONS						
	DRAWING NUMBER	300-7003	D	7353				

THE INFORMATION CONTAINED IN THIS DRAWING IS THE PROPERTY OF WANG LABORATORIES, INC. AND IS CONFIDENTIAL. IT MAY NOT BE COPIED, REPRODUCED, OR USED IN WHOLE OR IN PART FOR ANY REASON.

WANG LABORATORIES, INC.  
 280 WEST 42ND STREET  
 NEW YORK, N.Y. 10018



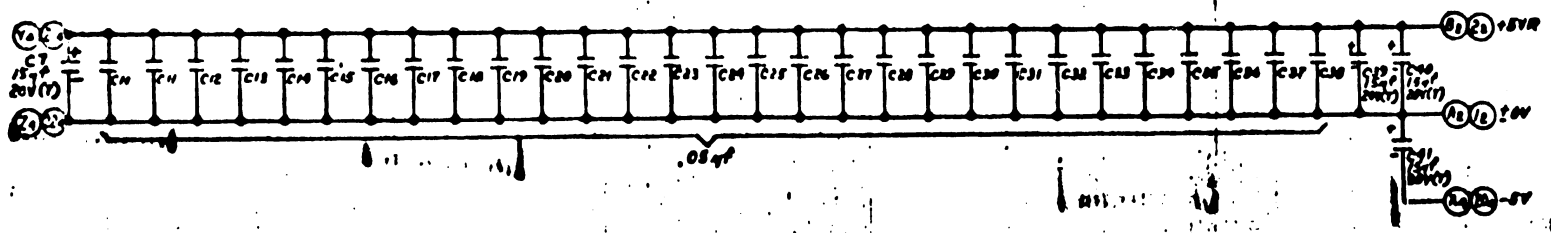
LOCATION	W.L. PART NO.	TYPE
L1A, 1B, 22, 30	376-0006	7474
L2, 8, 31	376-0010	7404
L3	376-0003	7410
L4, 20, 28	376-0081	7409
L5	376-0009	7420
L6, 9, 13, 27	376-0002	7400
L7, 10	376-0194	7411
L11, 33	376-0050	74180
L12, 12A, 17	376-01041	9602
L14	376-0226	74500
L15, 25, 32, 18	376-0093	7432
L16	376-0016	7402
L19	376-0233	745161
L21	376-0176	74567
L23, 24	376-0138	74298
L26	376-0053	74193
L29, 35, 36, 37	376-0097	74195
L30	376-0146	75107
L34	376-0098	74174
L37	376-0197	74504
L40, 41, 42	376-0202	74574
L43	376-0230	74510
L44	376-0237	74511
L45	376-0286	75113
L46, 49	376-0094	74161
L47, 48, 50, 51	376-0183	74173

COMPONENT	W.L. PART NO.	TYPE
DI	380-1001	514
SWI	325-1501	5 BANK PER
XTAL	321-0012	17.1 MHR
SIDI-E	333-0806	2.2K SIP RELS
R1	330-2040	390K 1/4W 5%
R2	330-2025	210K 1/4W 5%
R3	330-1052	310K 1/4W 5%
R4	330-2011	100K 1/4W 5%
RS, 6	330-2047	40K 1/4W 5%
R7, 11, 14	330-3022	2.2K 1/4W 5%
R8, 9, 12	330-4010	10K 1/4W 5%
R10	330-4007	81K 1/4W 5%
R13	330-4034	13K 1/4W 5%
R15	330-3027	2.7K 1/4W 5%
C1, 10-38	300-1900	0.05uF 12V
C2, 7, 39-41	300-4022	15uF 20V 5%
C3	300-1903	0.01uF 25V
C4	300-3010	50uF 50V
C5, 8	300-1220	220uF CER
C6	300-1906	0.01uF 200V
C9	300-5012	0.0022uF 150V 5%
C42	300-1930	1uF 50V

SIGNAL INDEX

W.L. PART NO.	DESCRIPTION
A0M-A10M	2C1
B1-B4	1D1
DM0-DM8	2F1
-DATA	1F11
+DATA	1F11
1B2	2F8
258BC	2E7
1BVTR	1B2
251 BVTR	1C2
CPF	2F9
LNAG	2B9
LNAR	2C7
INST	1C2
IP	2F10
AIR	1E9
MWT	2E1
2F3	1C2
PLG	1D3
25-EGC	2E8
RESTART	1C11
RSTRT	1C2
RTCC	2C5
SDIN	1F9
SDOUT	1B5
SMWT	1C2
SRCK	1E2
SYN	2G5
FRANS	2D6

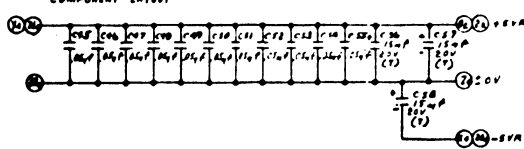
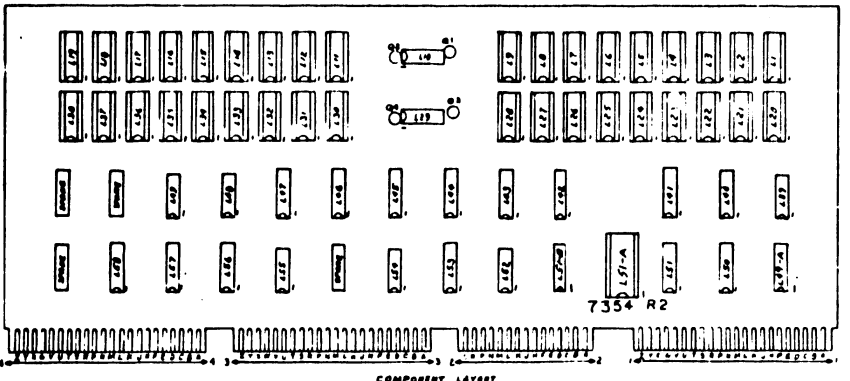
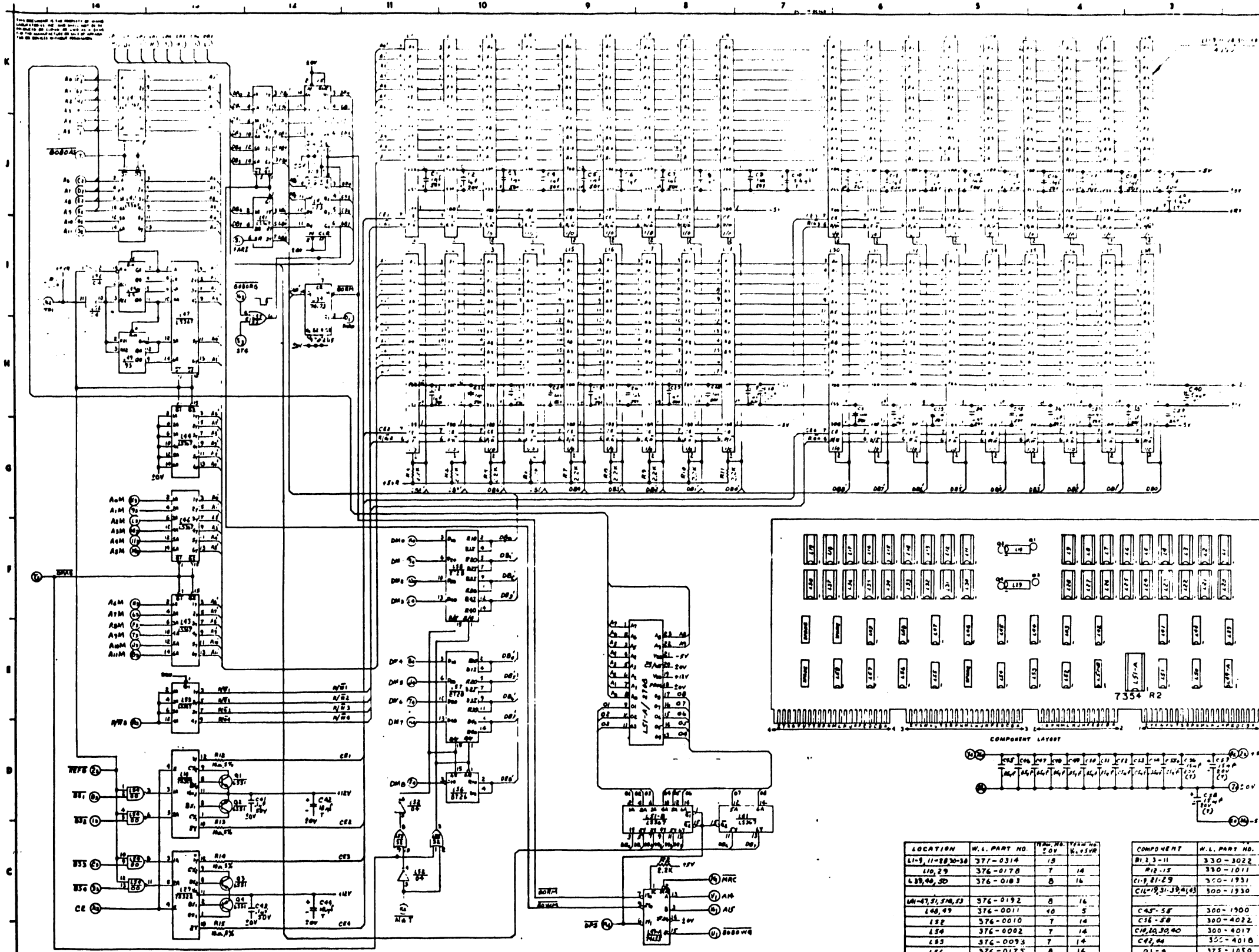
LOCATION	TYPE	SPARES
L2	7404	2
L1B	7432	3
L12A	9602	1
L13	7410	3
L14	74500	3
L27	7400	1
L28	7408	2
L33	74504	3
L44	74511	1



JUL 19 1978

REV	DESCRIPTION	DATE	BY	APPROVED BY
1	REVISED TO ADD PARTS L1, L2, L3, L4, L5, L6, L7, L8, L9, L10, L11, L12, L13, L14, L15, L16, L17, L18, L19, L20, L21, L22, L23, L24, L25, L26, L27, L28, L29, L30, L31, L32, L33, L34, L35, L36, L37, L38, L39, L40, L41, L42, L43, L44, L45, L46, L47, L48, L49, L50, L51	7/19/78		

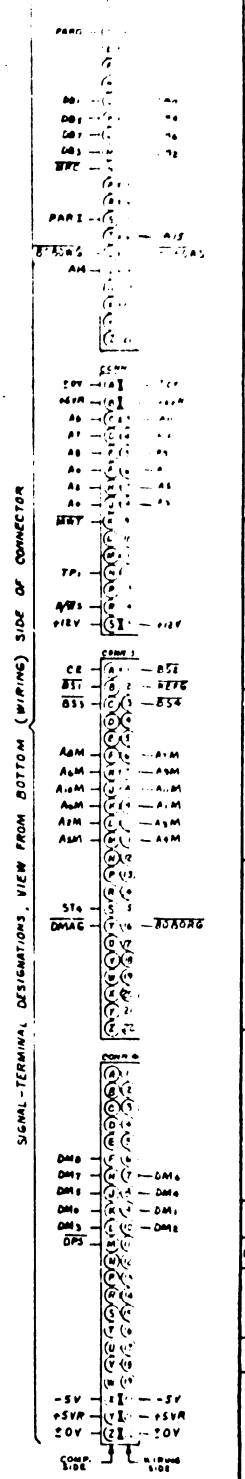
QTY	ITEM	WANG PART NO.	DRAWING NO.	DESCRIPTION	BY	DATE	APPROVED BY	DATE
		(WANG)						
				MODEL NO 728TCP				
				DATA LINK TELECOMMUNICATIONS				
				210-7353	D	7353		5



LOCATION	W.L. PART NO.	VAL.	TOL.	QTY
L1-5, 11-28, 30-38	377-0314	10		
L10, 29	376-0178	7	14	
L39, 44, 50	376-0183	8	16	
L4-47, 51, 56, 63	376-0192	8	16	
L48, 49	376-0011	10	5	
L52	376-0010	7	14	
L54	376-0002	7	14	
L55	376-0093	7	14	
L56	376-0175	8	16	
L57, 58	376-0279	8	16	
L49, 59	376-0099	8	16	
LS1-A	377-0317	12	24	

COMPONENT	W.L. PART NO.
R1, 3-11	330-3022
R12-15	330-1011
C1-9, 21-29	350-1931
C10-19, 31-39, 41, 43	300-1930
C45-58	300-1900
C36-50	300-4022
C10, 14, 30, 40	300-4017
C42, 44	350-4018
Q1-A	375-1050
11-17, 24, 30-38	376-9814
LS1	376-9003

LOCATION	TYPE	VALUES
L52	7404	2
L53	741367	2
L55	7432	1

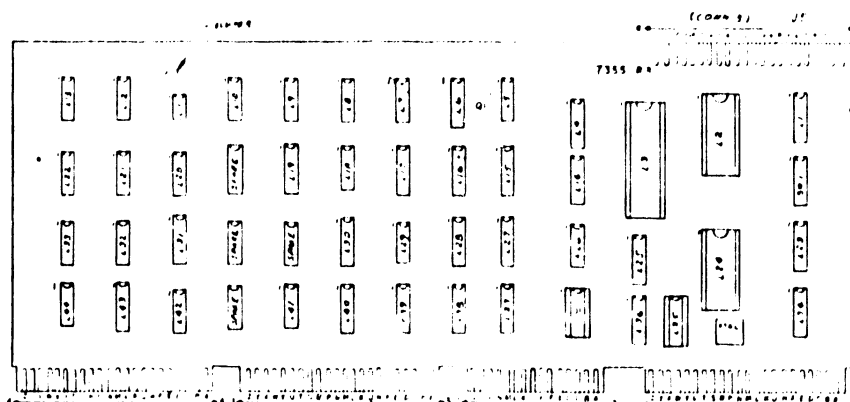
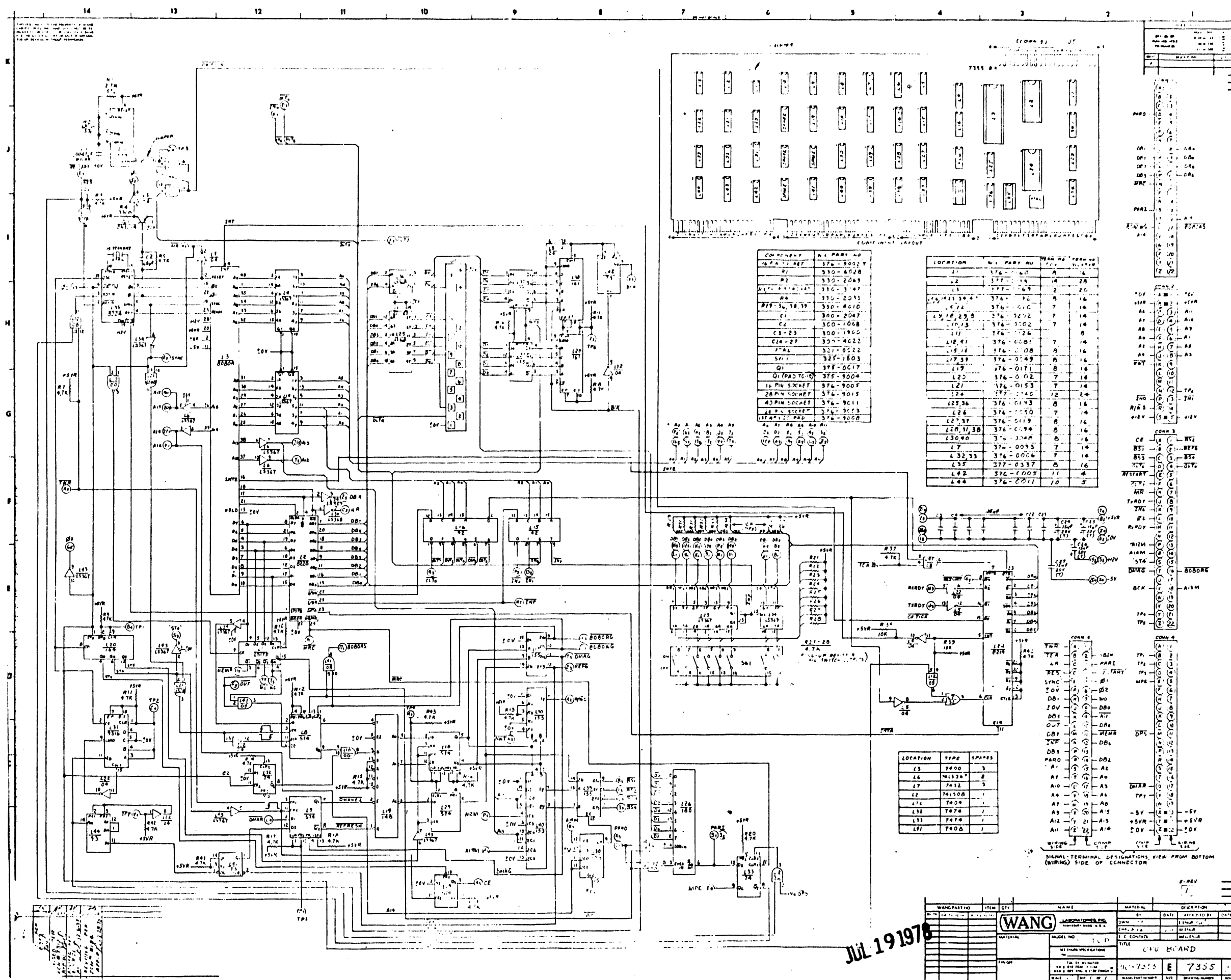


NO.	DESCRIPTION	DATE	BY
1	REVISED FOR...		
2	REVISED FOR...		
3	REVISED FOR...		

WANG PART NO.	ITEM	QTY	NAME	MATERIAL	DATE	BY	REV.
			<b>WANG</b>				

JUL 19 1978

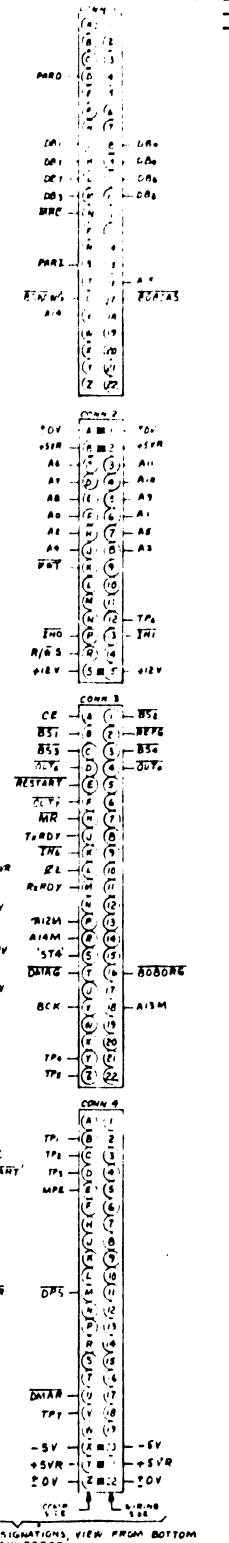




COMPONENT	QTY	PART NO.
16 PIN SOCKET	376-9004	1
28 PIN SOCKET	376-9015	1
43 PIN SOCKET	376-9011	1
24 PIN SOCKET	376-9013	1
118 PIN PAD	376-9008	1

LOCATION	QTY	PART NO.	REF. DES.	QTY
L1	1	376-0100	A	6
L2	1	377-0104	A	28
L3	1	377-0109	A	20
L4	1	376-0102	A	16
L5	1	376-0103	A	14
L6	1	376-0104	A	14
L7	1	376-0105	A	14
L8	1	376-0106	A	14
L9	1	376-0107	A	14
L10	1	376-0108	A	14
L11	1	376-0109	A	14
L12	1	376-0110	A	14
L13	1	376-0111	A	14
L14	1	376-0112	A	14
L15	1	376-0113	A	14
L16	1	376-0114	A	14
L17	1	376-0115	A	14
L18	1	376-0116	A	14
L19	1	376-0117	A	14
L20	1	376-0118	A	14
L21	1	376-0119	A	14
L22	1	376-0120	A	14
L23	1	376-0121	A	14
L24	1	376-0122	A	14
L25	1	376-0123	A	14
L26	1	376-0124	A	14
L27	1	376-0125	A	14
L28	1	376-0126	A	14
L29	1	376-0127	A	14
L30	1	376-0128	A	14
L31	1	376-0129	A	14
L32	1	376-0130	A	14
L33	1	376-0131	A	14
L34	1	376-0132	A	14
L35	1	376-0133	A	14
L36	1	376-0134	A	14
L37	1	376-0135	A	14
L38	1	376-0136	A	14
L39	1	376-0137	A	14
L40	1	376-0138	A	14
L41	1	376-0139	A	14
L42	1	376-0140	A	14
L43	1	376-0141	A	14
L44	1	376-0142	A	14

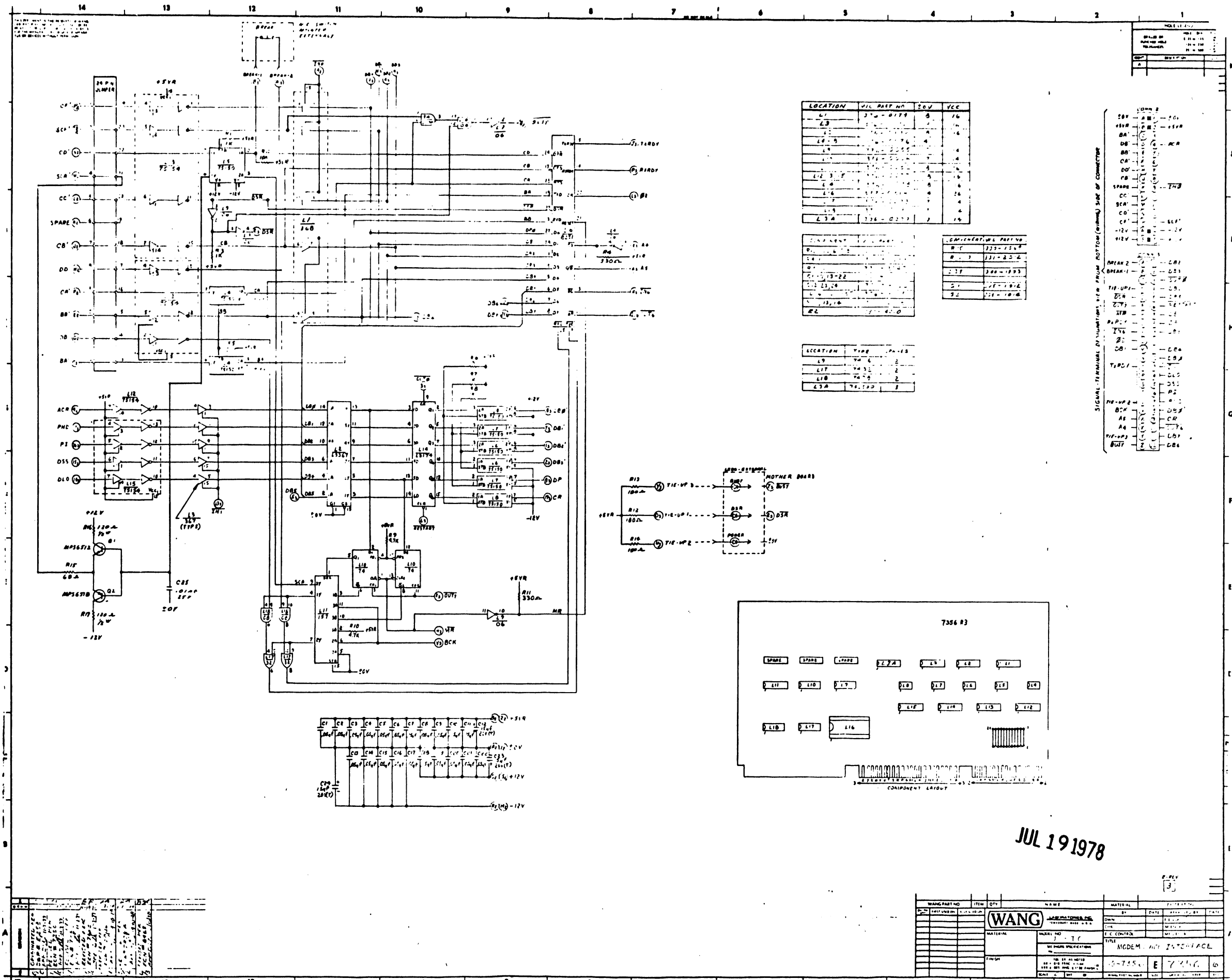
LOCATION	TYPE	SPARES
L5	7400	3
L6	7412	3
L7	7412	3
L8	7404	1
L9	7474	1
L10	7400	1



SIGNAL TERMINAL DESIGNATIONS, VIEW FROM BOTTOM (WIRING) SIDE OF CONNECTOR

JUL 19 1976

WANG PART NO.	ITEM	QTY	NAME	MATERIAL	DESCRIPTION
			<b>WANG</b>		
			LABORATORIES INC.		
			MODEL NO. 7355		
			TITLE		
			CPU BOARD		
			REV. 7355		
			7355		

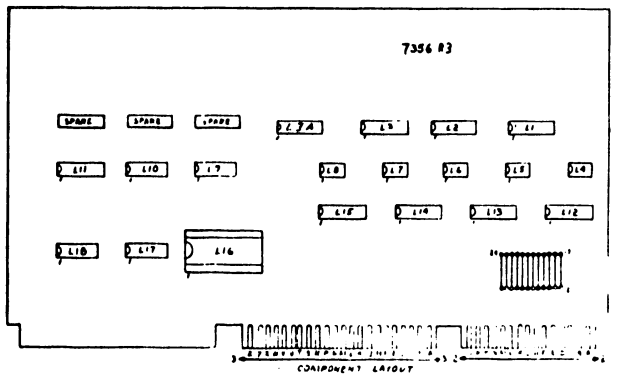
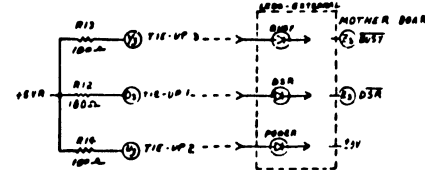
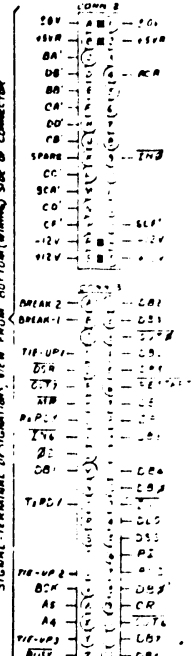


NO.	DESCRIPTION
1	
2	
3	
4	
5	
6	
7	
8	
9	
10	

LOCATION	WFL PART NO.	SOV	VCC
L1	374-0177	5	16
L2		4	14
L3		4	14
L4		4	14
L5		4	14
L6		4	14
L7		4	14
L8		4	14
L9		4	14
L10		4	14

LOCATION	TYPE	VALUES
L9	T	4.7K
L17	T	100Ω
L18	T	2
L19	T	2

LOCATION	WFL PART NO.	SOV	VCC
R1	333-124	4	14
R2	331-204	4	14
R3	308-193	4	14
R4	361-104	4	14
R5	324-104	4	14



JUL 19 1978

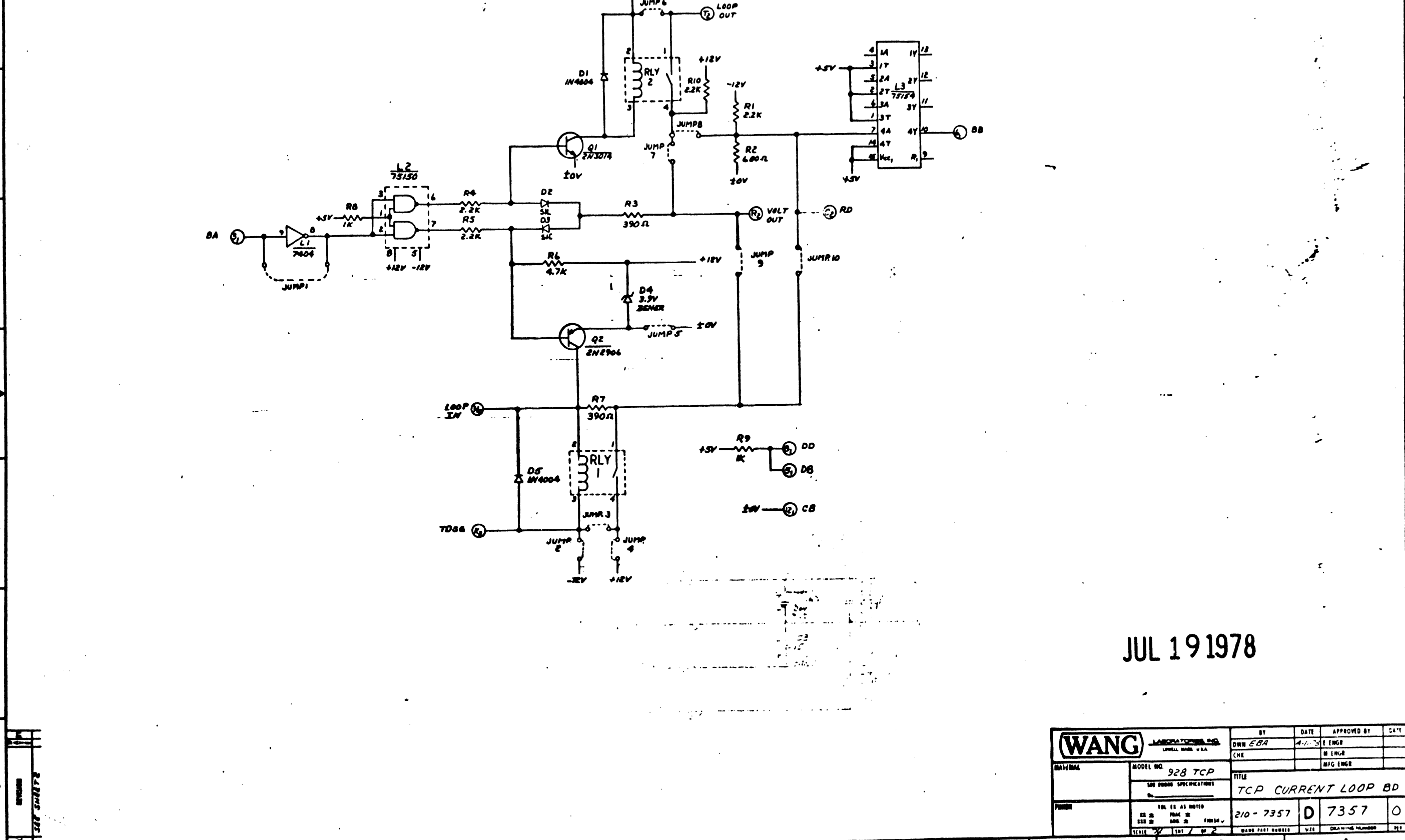
NO.	DESCRIPTION	DATE	BY
1			
2			
3			
4			
5			

WANG PART NO.	ITEM	QTY.	NAME	MATERIAL	DATE	BY	DATE
307450	1		MODEM INTERFACE				
307450	2						
307450	3						
307450	4						



11 10 9 8 7 6 5 4 3 2 1

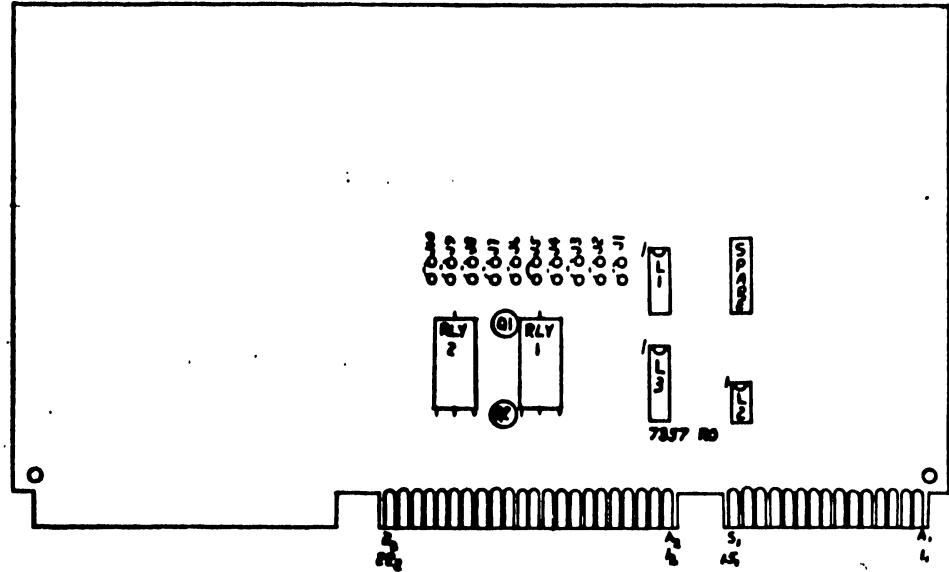
"THIS DRAWING AND THE DATA SHOWN THEREON ARE THE CONFIDENTIAL PROPERTY OF AND ARE PROPRIETARY TO WANG LABORATORIES, INC. THE DRAWING AND THE DATA SHOWN THEREON MAY NOT BE MADE PUBLIC WITHOUT THE WRITTEN CONSENT OF WANG LABORATORIES, INC. IF FOR ANY REASON THIS DRAWING IS FURNISHED BY WANG TO LEASEE OR OTHER PARTY OF THE COMPANY IT IS RETURNABLE UPON THE DEMAND OF WANG LABORATORIES, INC."



JUL 19 1978

<b>WANG</b> LABORATORIES, INC. LOWELL, MASS. U.S.A.		BY	DATE	APPROVED BY	CA'T
		DWN EBA	4-1-78	E ENGR	
MODEL NO. 928 TCP TCP BOARD SPECIFICATIONS		CHE		M ENGR	
				DIG ENGR	
TITLE		TCP CURRENT LOOP BD			
PART NO.		210-7357	D	7357	0
SCALE 1/8" = 1"		SHEET 1 OF 2		WANG PART NUMBER	SIZE

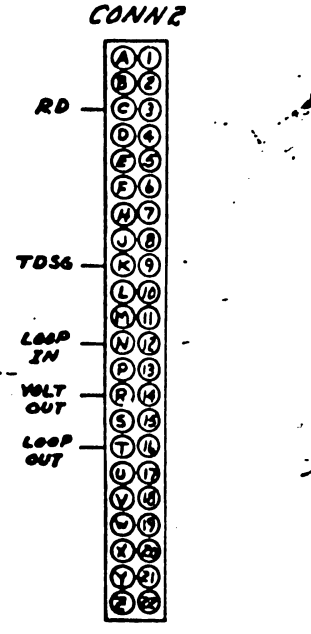
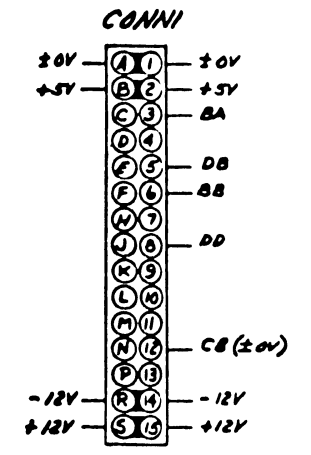
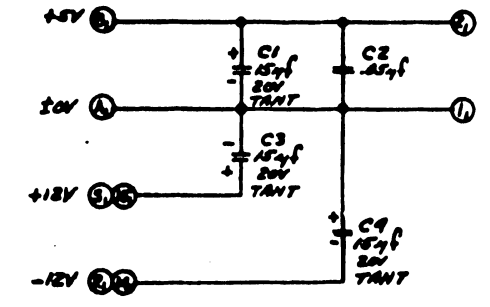
THIS DRAWING AND THE DATA SHOWN THERE  
 ARE THE CONFIDENTIAL PROPERTY OF AND  
 PROPRIETARY TO WANG LABORATORIES  
 INC. THIS DRAWING AND THE DATA SHOWN  
 HEREIN MAY NOT BE MADE PUBLIC WITHOUT  
 THE WRITTEN CONSENT OF WANG LABORATORIES  
 INC. IN NO EVENT SHALL THE DRAWING BE  
 REPRODUCED BY ANY OTHER PARTY WITHOUT  
 THE WRITTEN CONSENT OF WANG LABORATORIES  
 INC. IF THIS DRAWING IS RETURNED TO  
 WANG LABORATORIES INC. THE DRAWING IS TO BE  
 DESTROYED BY WANG LABORATORIES INC.



COMPONENT	W.L. PT. NO.	TYPE
C1,3,4	300-4022	15 $\mu$ f (T)
C2	300-1900	.05 $\mu$ f
D1,5	380-4000	1N 4004
D2,3	380-1001	51L
D4	380-2039	3.9V ZENER
Q1	375-0017	2N 3014
Q2	375-1017	2N 2906
R1,4,5,10	330-3022	2.2K 10%
R2	330-2060	600 $\Omega$ 10%
R3,7	330-2039	390 $\Omega$ 10%
R6	330-3047	4.7K 10%
R8,9	330-3010	1K 10%
RLY1,2	380-0062	MERCURY

SPARES		
LOCATOR	TYPE	NO.
L1	7404	5

LOCATION	W.L. PT. NO.	TYPE
L1	376-0010	7404
L2	376-0076	7515D
L3	376-0077	75154



JUL 19 1978

G.R.S.V.  
 0

<b>(WANG)</b> LABORATORIES INC. LOCAL MADE USA		BY OWN EBA	DATE 7/19/78	APPROVED BY E ENGE	DATE 7/20/78
MODEL NO. 928 TCP		CHE		MFG ENGR	
SEE ORDER SPECIFICATIONS		TITLE TCP CURRENT LOOP			
FIG. NO. 11 11 11 11 11		210-7357		D	7357
PAGE 2 OF 2		DRAWING NUMBER		REV.	

THE INFORMATION CONTAINED IN THIS DRAWING IS THE PROPERTY OF WANG LABORATORIES, INC. AND IS CONFIDENTIAL AND PROPRIETARY TO WANG LABORATORIES, INC. IT MAY NOT BE COPIED, REPRODUCED OR USED IN WHOLE OR IN PART FOR ANY REASON.

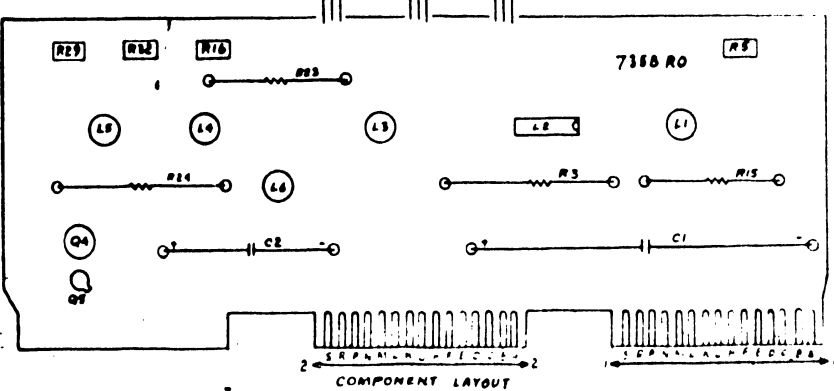
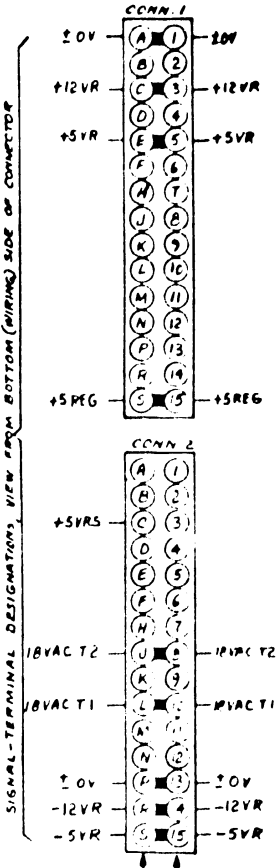
DIMENSIONS IN PARENTHESES TOLERANCES TO BE EQUIVALENT TO SUCH DIMENSIONS.

HOLE LEGEND & TOLERANCE	
HOLE NO.	
118	DEPTH
2	

LOCATION	W.L. PART NO.	QTY.
L1,3	376-0066	5
L2	376-0240	
L4,5	376-0134	9
L6	376-0074	

COMPONENT	W.L. PART NO.
R1,2	332-3010
R3	334-0002
R4	330-2068
R6,12,22,31	330-3018
R7,18,34	330-3033
R8,17,25	330-3022
R9	337-2039
R10,14,30	330-5012
R11	330-3018
R13	330-5010
R15	334-0015
R21	330-1022
R23	334-0014
R24	334-0003
R26	330-1027
R27	330-4033
R28	330-2082
R29,32	336-1022
R33	330-3056
C1	300-3078
C2	300-3021
C3,4,8,9	300-1915
C5,6,7,10,13,14	300-1900
C12,18	300-1906
C15	300-4032
C11,16	300-4022
D1,2	380-3008
D3,4	380-4000
D5-9	380-1001
D10	380-2129
Q1,2	375-1052
Q3	375-1053
Q4	375-1024
Q5	375-1017
C17	300-4018
R5,16	336-1014
R20	330-3027
R19	330-3010

LOCATION	TYPE	SPARES
L2	LM339	2



JUL 19 1978

E-REV

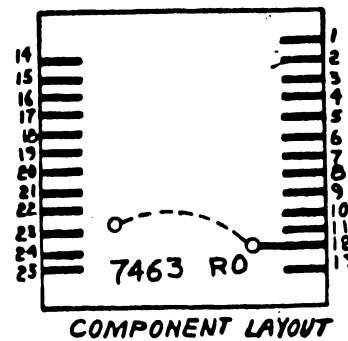
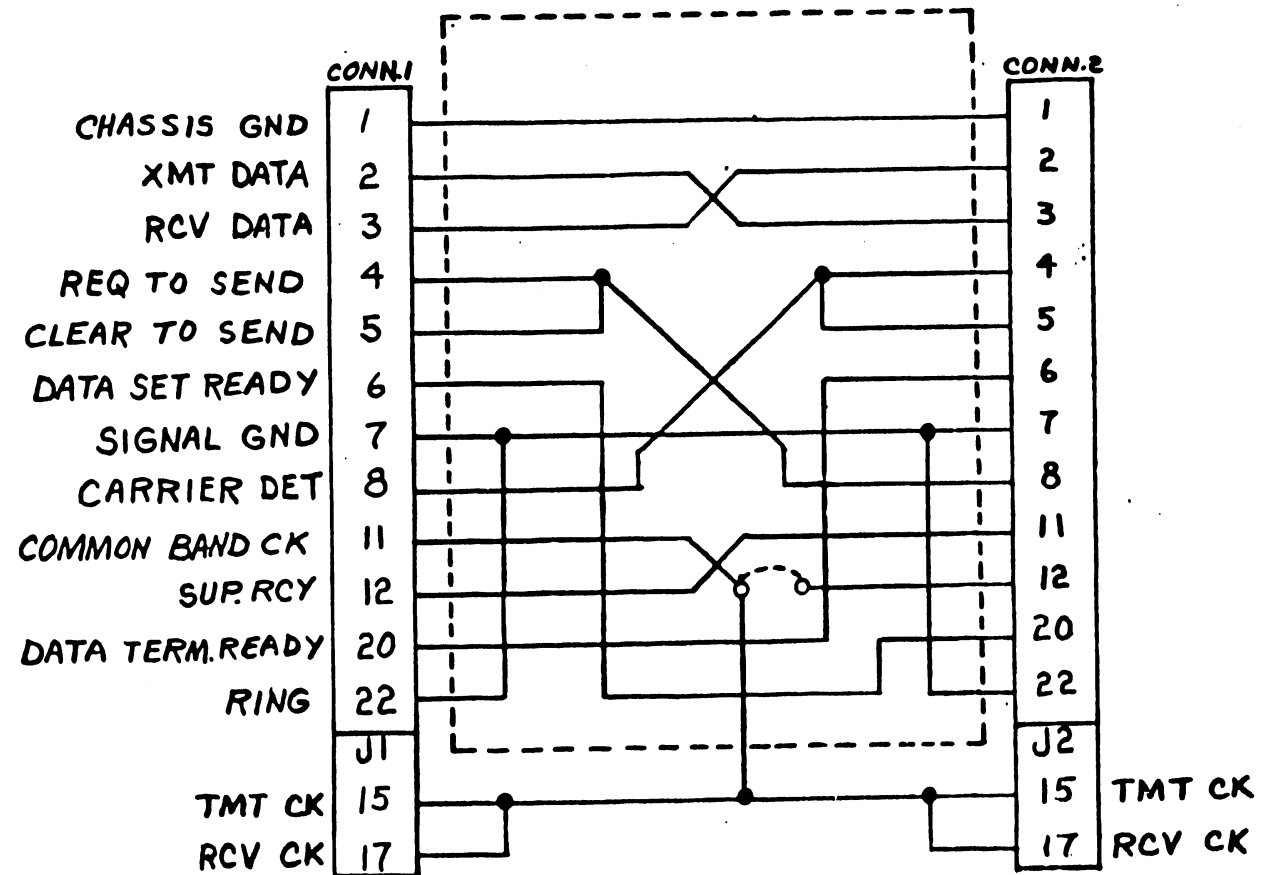
REV	QTY	ITEM	WANG PART NO.	DRAWING NO.	DESCRIPTION	BY	DATE	APPROVED BY	DATE
1									
<p>ORIGINATED MR. [unclear]</p> <p>DRAWN BY [unclear]</p> <p>APP'D BY [unclear]</p> <p>REVISOR [unclear]</p> <p>PCB [unclear]</p> <p>APP'D BY [unclear]</p>						<p>WANG LABORATORIES, INC.</p> <p>TEMPERLEY, MASS. U.S.A.</p> <p>MODEL NO. 4-CP</p> <p>SEE INCH SPECIFICATIONS</p> <p>TITLE: REGULATOR</p> <p>210-735F D 7358 1</p>			



"THIS DRAWING AND THE DATA SHOWN THEREON ARE THE CONFIDENTIAL PROPERTY OF, AND ARE PROPRIETARY TO, WANG LABORATORIES, INC.; THIS DRAWING AND THE DATA SHOWN THEREON MAY NOT BE MADE PUBLIC WITHOUT THE WRITTEN CONSENT OF WANG LABORATORIES, INC. IF FOR ANY REASON THIS DRAWING IS PERMITTED BY WANG TO LEAVE THE PHYSICAL CUSTODY OF THE COMPANY, IT IS RETURNABLE UPON THE DEMAND OF WANG LABORATORIES, INC."

DO NOT SCALE

COMPONENT	WL PART NO	TYPE
CONN. 1, 2	350-1031	DB-255 CH CONN



JUL 19 1978

E-REV  
0

NO	REVISION	BY	DATE
0	ORIGINATED PER DWR # E 159 APP'D: HD, 5-2-78	CK	4-7-78

<b>WANG</b> LABORATORIES, INC. LOWELL, MASS. U.S.A.		BY	DATE	APPROVED BY	DATE
		DWN <i>CK</i>	4-7-78	E ENGR K. OSBORN	5-2-78
MATERIAL MODEL NO. 928 SEE ENGRG SPECIFICATIONS No. _____ FINISH TOL. EX. AS NOTED .XX ± .010 FRAC. ± 1/64 .XXX ± .005 ANG. ± 1°30' FINISH ✓		CHK <i>HD</i>	5-2-78	M ENGR	
		E. C. CONTROL		MFG ENGR	
		TITLE BI-SYNC NULL MODEM BOARD			
		210-7463	B	7463	0
SCALE		SHT / OF /	WANG PART NUMBER	SIZE	DRAWING NUMBER
					REV



LABORATORIES, INC

---

ONE INDUSTRIAL AVENUE, LOWELL, MASSACHUSETTS 01851. TEL. (617) 459-5000. TWX 710 343-6769. TELEX 94-7421

PRINTED IN U.S.A.

**END**